

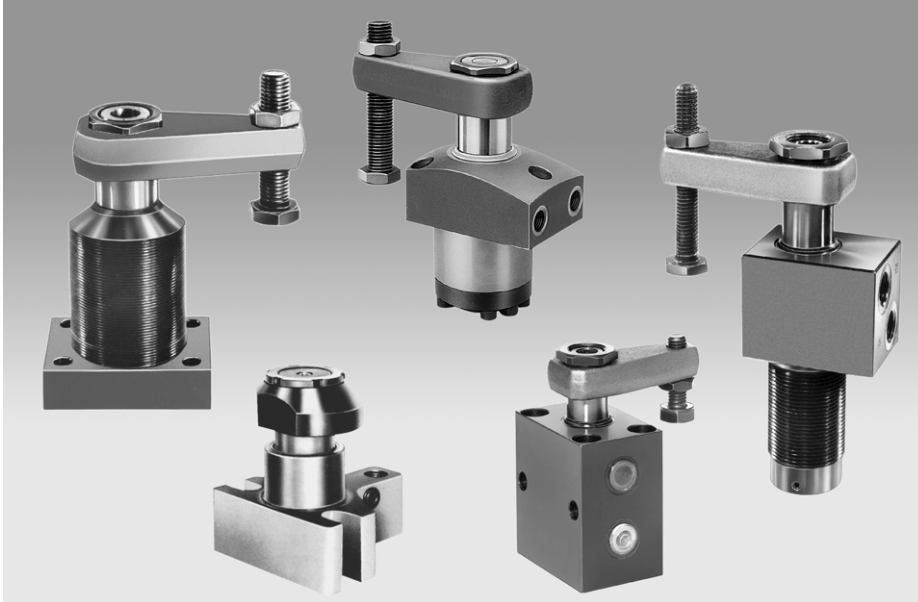

Operating Instructions Swing Clamps



Swing clamps

- with overload protection device
- with hydraulic port and tubes or with hydraulic manifold mounting port
- without position monitoring

These operating instructions are available for swing clamps of the following types:

1882-xxx	1892-xxx
1883-xxx ¹	1893-xxx ²
1885-xxx ¹	1895-xxx ^{2, 3}
1886-xxx	1896-xxx ³
1887-xxx ¹	1897-xxx ^{2, 3}

¹ except -xx2

² except -xx1

³ except -VMHxx

Target group of this document

Fitters and setters of machine tools. They have to be familiar with the handling of hydraulic power workholding components.

Provided use

Hydraulic clamping of workpieces on machine tools. Use only hydraulic oil. Only clamping arms may be moved.

Safety



Danger of crushing

Keep hands and other parts of the body out of the swing and clamping area!

- Select the clamping position within the clamping stroke (P2). Clamping is not permitted within swing stroke (P1). There is no clamping force in the stroke end position.
- Design of the clamping force must be higher than the machining force.
- Design clamping arm and operating pressure for the clamping force as per Römheld data sheet.

Instructions for safe operation



Material damage

Avoid collisions of the swing clamp with the workpiece. Thereby the swing clamp can be damaged.

- Swarf or contamination in the hydraulic oil lead to increased wear or damage at the guides, running surfaces and seals.
- Clamping and support points at the workpiece must be free of swarf to guarantee an exact and safe clamping.
- Use hydraulic oil as per Römheld data sheet A 0.100.

Function

This hydraulic clamping element is a pull-type cylinder where a part of the total stroke is used to swing the piston. Thereby the clamping area is free for loading and unloading of the fixture. An installed overload protection device protects the swing mechanism when striking an object within the angle of rotation or in case of incorrect mounting of the clamping arm.

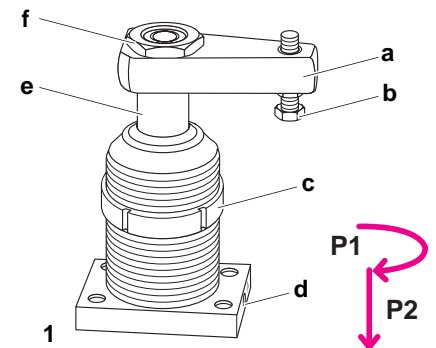

a Clamping arm (accessory)

b Contact bolt (accessory)

c Collar nut (accessory)

d Hydraulic ports A + B

e Piston with integrated piston rod

f Fixing nut (included in delivery)

P1 Swing stroke

P2 Clamping stroke

Angle and direction of rotation

The swing clamps are available with angles of rotation of 0° up to 90°. Direction of rotation means clockwise rotation, looking from above onto the piston.

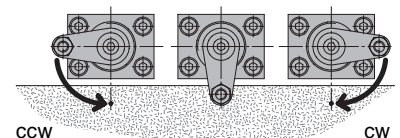

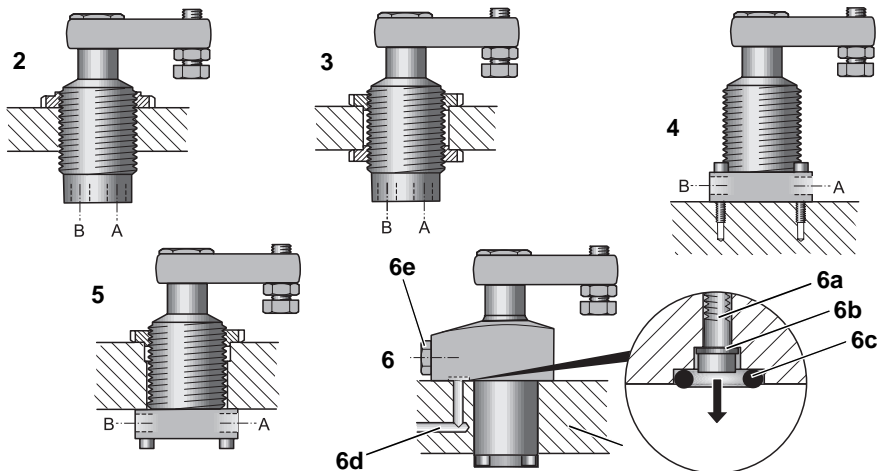

All figures are schematic figures.

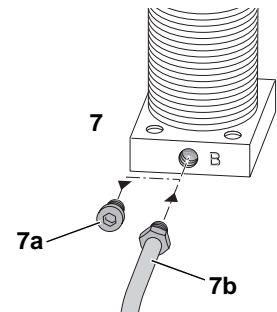

Install swing clamp

Threaded-body version

- ◆ Produce thread in the fixture and lock the swing clamp with a collar nut(2).
- or:
- ◆ Fasten the swing clamp in the through hole with two collar nuts(3).

Flange-type version (hydraulic port and tubes)

- ◆ Clean the support surfaces.
- ◆ Fasten the swing clamp at the flange(4).

or:

- ◆ Fasten the swing clamp at the flange or/ and in the through hole by collar nuts (5). In most cases one of the two types of fixing are sufficient.

Flange version (hydraulic connection without tubes)

- ◆ Drill holes (6d) for hydraulic oil supply and return in the fixture.
- ◆ For version "flange at the top" (18xx-xx3) in addition:
 - ◆ Remove socket head cap screws (6a) and Usit-rings (6b). Insert O-rings (6c, part-no. 3000-347).
 - ◆ Seal ports A and B with two plugs G1/4 (6e, part-no. 3610-006).
- ◆ Clean the support surfaces.
- ◆ Fasten swing clamp on the fixture.

Hydraulic connection

- ◆ Connect hydraulic lines to qualifying standards, pay attention to scrupulous cleanliness! See also Römheld data sheets A0.100, F9.300, F9.310 and F9.360.
- ◆ Use only fittings "screwed plug B" as per DIN 3852 (ISO 1179).
- ◆ Do not use sealing tape, copper rings or coned fittings.
- ◆ Check sealing of the hydraulic connections!

Port	Function
A	Clamping (retract)
B	Unclamping (in case of double-acting swing clamps 189x). Bleeding (in case of single-acting swing clamps 188x).

Hydraulic bleeding

Bleed the hydraulic lines during start-up of the system, otherwise clamping times can be considerably prolonged and function problems can be caused.

Hydraulic port and tubes

- ◆ Loosen carefully at low pressure union nut of the tube at the hydraulic ports.
- ◆ Pump until bubble free oil comes out.
- ◆ Fasten union nuts of the tube.

Hydraulic connection without tubes (O-ring sealing)

Install a bleeding screw at the upper ends of the piping.

- ◆ Loosen carefully at bleeding screws at the hydraulic ports.
- ◆ Pump until bubble free oil comes out.
- ◆ Fasten the bleeding screws.

Single-acting swing clamps

The spring area of single-acting swing clamps (188x) must be vented (pressure compensation). A sintered metal air filter avoids penetration of dust and swarf. If there is any danger of fluids being sucked into the filter, a vent hose has to be connected.

- ◆ Unscrew plug with sintered metal air filter (7a) from port B.
- ◆ The vent hose (7b) has to be placed in a position where definitely no liquids can enter. See also Römheld data sheet A 0.110.



Troubles of functioning

Protect the bleeding port (port B) against penetration of coolants and cutting fluids!

Subject to changes without notice.

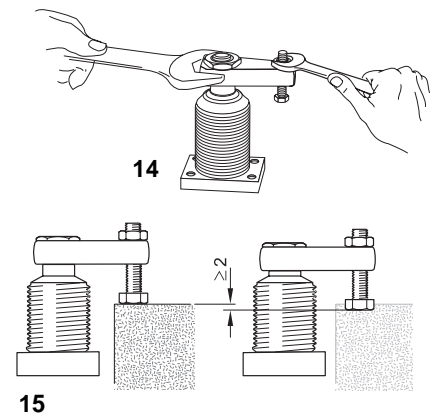
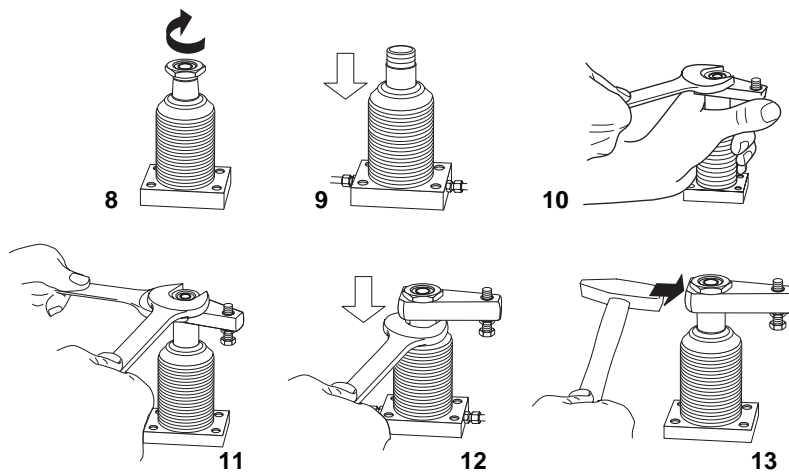

Mounting of the clamping arm – with pressure



Contamination

The piston and the clamping arm must be clean and grease free!

- Check overload protection device: Turn the fixing nut, until the piston snaps in (8). The overload protection device has two positions for engagement at a distance of 180°.
- Retract piston and pressurise clamping line (port A)(9).
- Put the clamping arm in the intended clamping position and fasten fixing nut (10).
- Clamp several times. Check if the clamping point is within the clamping stroke (P2).



Danger of crushing

Keep hands and other parts of the body out of the swing and clamping area!

Dismounting - with pressure

- Turn the fixing nut by 1 rotation, hold arm with open-ended spanner(11).
- Put the spanner below the clamping arm.
- Clamp the piston to loosen the clamping arm (12).

Mounting of the clamping arm – without pressure



Danger of crushing

Keep hands and other parts of the body out of the swing and clamping area!

Dismounting – without pressure

- Turn the fixing nut by 1 rotation, hold arm with open-ended spanner (11).
- Hammer **lightly** against the front face to loosen the clamping arm (13).



Sensitive parts

Heavy hammering can destroy the piston rod guide!

Adjustment of contact bolt

- Loosen the lock nut at the contact bolt, hold arm with open-ended spanner at the piston end (14).
- Adjust the contact bolt so that the contact bolt contacts the workpiece only after completion of the swing motion and if there are still at least 2 mm of clamping stroke (P2) available as reserve (15).

- Tighten the lock nut at the contact bolt, hold arm with open-ended spanner (14).

Maintenance

Check if the hydraulic ports are tight (visual control). The swing clamp itself is maintenance free.

Data sheets

Types	Corresponding data sheets
18x2	B1.883
18x3	
18x5	B1.880
18x6	B1.881
18x7	

Key for different types

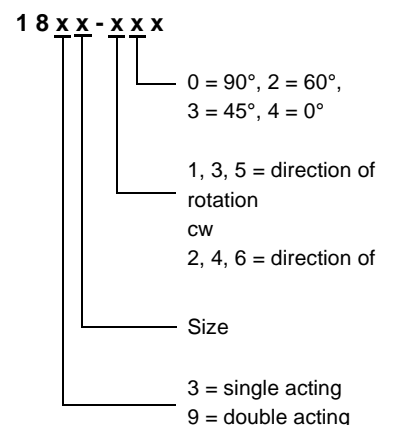

Subject to changes without notice.



General characteristics

Part-no.		18x2-xxx	1883-xx1	1885-xx1	1887-xx1	1893-xx6	1895-xx6	1897-xx6	18x3-1x3 18x3-2x3 18x3-xx4	1893-xx8 1893-3x3 1893-4x3	1893-xx9 1893-5x3 1893-6x3
Total stroke (P1 + P2)	mm	14	14	16	20	14	16	20	18	34	59
Swing stroke (P1)	mm	7	7	8	9	7	8	9	7	9	9
Clamping stroke (P2)	mm	7	7	8	11	7	8	11	11	25	50
Operating pressure, min.	bar	50	30	30	30	30	30	30	30	30	30
Operating pressure, max.	bar	500	500	500	500	500	500	500	500	500	500
Admissible oil flow rate	cm ³ /s	1,5	3,2	10	27,7	3,2	10	27,7	3,2	3,2	3,2
Declutch moment of overload protection	Nm	3,5	3,5	11	22	3,5	11	22	3,5	3,5	3,5
Seating torque fixing nut of the clamping arm	Nm	30	30	90	280	30	90	280	30	30	30
Tolerance of end position	°	± 2	± 2	± 2	± 2	± 2	± 2	± 2	± 2	± 2	± 2

Part-no.		18x5-1x3 18x5-2x3 18x5-xx4	1895-xx8 1895-3x3 1895-4x3	1895-xx9 1895-5x3 1895-6x3	18x6-1x3 18x6-2x3 18x6-xx4	1896-xx8 1896-3x3 1896-4x3	1896-xx9 1896-5x3 1896-6x3	18x7-x03 {18x7-x04}	{1897-xx8} 1897-3x3 1897-4x3	{1897-xx9} 1897-5x3 1897-6x3
Total stroke (P1 + P2)	mm	22	35	60	26	36	61	24	37	62
Swing stroke (P1)	mm	8	10	10	11	11	11	9	12	12
Clamping stroke (P2)	mm	14	25	50	15	25	50	15	25	50
Operating pressure, min.	bar	30	30	30	30	30	30	30	30	30
Operating pressure, max.	bar	500	500	500	500	500	500	500	500	500
Admissible oil flow rate	cm ³ /s	10	10	10	18,4	18,4	18,4	27,7	27,7	27,7
Declutch moment of overload protection	Nm	11	11	11	17	17	17	22 {30}	22 {30}	22 {30}
Seating torque fixing nut of the clamping arm	Nm	90	90	90	160	160	160	280	280	280
Tolerance of end position	°	± 2	± 2	± 2	± 2	± 2	± 2	± 2	± 2	± 2

Further data see Römheld data sheet.

Admissible oil flow rate

The max. oil flow rate is valid for vertical mounting positions in connection with standard clamping arms. Using this flow rate the shortest clamping time is one second. Reduce the flow rate for other mounting positions and/or clamping arms.

If the flow rate of the pump divided by the number of swing clamps is higher than the admissible oil flow rate, the flow rate has to be throttled to avoid any overload and thereby higher wear. For this purpose flow control check valves have to be mounted in the clamping line (port A) which allow oil return from the swing clamps without any impediments.

Special clamping arm

When using special clamping arms with other lengths, the corresponding operating pressures as shown in the clamping force diagram (see Römheld data sheets) must not be exceeded. If longer clamping arms will be used, not only the operating pressure but also the flow rate have to be reduced.

Trouble shooting

Trouble	Cause / Remedy
Piston rod with clamping arm does not retract	Clamping pressure not available or too low - Check at the pressure generator, if pressure is available and high enough (minimum pressure 30 bar)
Angle of rotation is not completely effected or exceeded (tolerance of end position ± 2°)	Oil flow rate too large - Reduce oil flow rate, insert throttle, if required Piston rod is not engaged in the guide - Turn the piston rod, until the overload protection device snaps in.
Single-acting swing clamp retracts too slowly	Flow resistance too big - Increase tube size, shorten the line Too many elements are connected - Use double-acting elements Hydraulic oil too thick - Use hydraulic oil with less viscosity Internal corrosion, e. g. by penetrated coolants - Exchange swing clamp
In the case of single-acting swing clamps liquids come out at the bleeding screw	Element draws off coolants and cutting liquids through the bleeding port. - Protect the vent opening against liquids, if required connect a vent hose - Wear at internal seals, exchange seals
Piston rod has play	Guide or piston rod are worn out - Exchange piston rod, exchange component, if required
Clamping pressure reduces due to leakages at the swing clamp	Wear at the seals - Exchange seals

Subject to changes without notice.