



Rotary Valve Couplings

Nominal diameter 5, max. operating pressure 500 bar



1 Description of the product

Description

Rotary valve couplings are used if several fixtures have to be supplied on rotary indexing systems. Provided that clamping and unclamping will be made always in the same place and the fixtures are arranged in a uniform way on the rotating plate. Clamping and unclamping is made by 1 off - or in the case of double-acting cylinders by 2 off 3/2 directional control valves, which are arranged outside the rotating system. Since in the unclamped position there is a continuous leakage to the return line, we recommend to use an accumulator for applications with operation pressures of up to 200 bar, for applications with operating pressures exceeding 200 bar an accumulator is required.

2 Validity of the documentation

This document applies to the following products:

Rotary valve couplings of the data sheet F 9.290. The following types or part numbers are concerned:

Loading and unloading in one station:

- 9295 001, 002 number of stations 5
- 9296 001, 002 number of stations 6
- 9297 001, 002 number of stations 7
- 9298 001, 002 number of stations 8
- 9299 001, 002 number of stations 9
- 9290 001, 002 number of stations 10

001 single-acting cylinders

002 double-acting cylinders

Loading and unloading in two stations - commonly controlled:

- 9396 011, 012 number of stations 6
- 9298 011, 012 number of stations 8
- 9290 011, 012 number of stations 10

011 single-acting cylinders

012 double-acting cylinders

Loading and unloading in two stations - separately controlled:

- 9296 101, 102 number of stations 6
- 9298 101, 102 number of stations 8
- 9290 101, 102 number of stations 10

101 single-acting cylinders

102 double-acting cylinders

Table of contents

1	Description of the product	1
2	Validity of the documentation	1
3	Target group of this document	2
4	Safety instructions	2
5	For your safety	2
6	Application	3
7	Installation	3
8	Start up	5
9	Maintenance	5
10	Trouble shooting	6
11	Technical characteristics	6
12	Accessory	6
13	Storage	7
14	Disposal	7
15	Declaration of manufacture	7

3 Target group of this document

- Specialists, fitters and set-up men of machines and installations with hydraulic expert knowledge.

Qualification of the personnel

Expert knowledge means that the personnel must

- be in the position to read and completely understand technical specifications such as circuit diagrams and product-specific drawing documents,
- have expert knowledge (electric, hydraulic, pneumatic knowledge, etc.) of function and design of the corresponding components.

An **expert** is somebody who has due to its professional education and experiences sufficient knowledge and is familiar with the relevant regulations so that he

- can judge the entrusted works,
- can recognize the possible dangers,
- can take the required measures to eliminate dangers,
- knows the acknowledged standards, rules and guidelines of the technology.
- has the required knowledge for repair and mounting.

4 Safety instructions

DANGER

Danger of life / heavy health damages

Stands for an imminent danger.

If it is not avoided, death or very severe injuries will result.

WARNING

Person damage

Stands for a possibly dangerous situation.

If it is not avoided, death or very severe injuries will result.

CAUTION

Easy injuries / property damage

Stands for a possibly dangerous situation.

If it is not avoided, minor injuries or material damages will result.

Hazardous to the environment

The symbol stands for important information for the proper handling with materials that are hazardous to the environment.

Ignoring these notes can lead to heavy damages to the environment.



Mandatory sign!

The symbol stands for important information, necessary protection equipment, etc.

NOTE

This symbol stands for tips for users or especially useful information. This is no signal word for a dangerous or harmful situation.

5 For your safety

5.1 Basic information

The operating instructions serve for information and avoidance of dangers when installing the products into the machine as well as information and references for transport, storage and maintenance.

Only in strict compliance with these operating instructions, accidents and property damages can be avoided as well as trouble-free operation of the products can be guaranteed.

Furthermore, the consideration of the operating instructions will:

- avoid injuries
- reduce down times and repair costs,
- increase the service life of the products.

5.2 Safety instructions

The product was manufactured in accordance with the generally accepted rules of the technology.

Observe the safety instructions and the operating instructions given in this manual, in order to avoid personal damage or material damage.

- Read these operating instructions thoroughly and completely, before you work with the product.
- Keep these operating instructions so that they are accessible to all users at any time.
- Pay attention to the current safety regulations, regulations for accident prevention and environmental protection of the country in which the product will be used.
- Use the ROEMHELD product only in perfect technical condition.
- Observe all notes on the product.
- Use only accessories and spare parts approved by the manufacturer in order to exclude danger to persons because of not suited spare parts.
- Respect the intended use.

- You only may start up the product, when it has been found that the incomplete machine or machine, in which the product shall be mounted, corresponds to the country-specific provisions, safety regulations and standards.
- Perform a risk analysis for the incomplete machine, or the machine.

Due to the interactions between the product and the machine/fixture or the environment, risks may arise that only can be determined and minimized by the user, e.g. :

- generated forces,
- generated movements,
- Influence of hydraulic and electrical control,
- etc.

6 Application

6.1 Intended use

The rotary couplings are used in industrial applications to transmit hydraulic or pneumatic pressure for one or several fixtures to rotating or swivelling equipments.

They are mounted in the centre of rotation of the equipment (e.g. rotary indexing tables).

Furthermore the following are possible uses:

- Use within the capacity indicated in the technical characteristics (see data sheet).
- Use as per operating instructions.
- Compliance with service intervals.
- Qualified and trained personnel for the corresponding activities.
- Mounting of spare parts only with the same specifications as the original part.

6.2 Misapplication

⚠ WARNING

Injuries, material damages or malfunctions!

- Do not modify the product!

The use of these products is not admitted:

- For domestic use.
- On pallets or machine tool tables in primary shaping and metal forming machine tools.
- If due to vibrations or other physical / chemical effects damages of the products or seals can be caused.
- In machines, on pallets or machine tool tables that are used to change the characteristics of the material (magnetise, radiation, photochemical procedures, etc.).
- In areas for which special guidelines apply, especially in installations and machines:
 - For the use on fun fairs and in leisure parks.
 - In food processing or in areas with special hygiene regulations.
 - For military purposes.
 - In mines.
 - In explosive and aggressive environments (e.g. ATEX).
 - In medical engineering.
 - In the aerospace industry.
 - For passenger transport.
- For other operating and environmental conditions e.g.:
 - Higher operating pressures than indicated on the data sheet or installation drawing.
 - With hydraulic fluids that do not correspond to the specifications.

Special solutions are available on request!

7 Installation

⚠ WARNING

Injury by high-pressure injection (squirting out of hydraulic oil under high pressure)!

- Improper connection can lead to escapes of oil under high pressure at the connections.
- Mounting or dismantling of the element must only be made in depressurised mode of the hydraulic system.
- Connection of the hydraulic line as per DIN 3852/ISO 1179.
- Unused connections have to be locked professionally.
- Use all mounting holes.

Injury by high-pressure injection (squirting out of hydraulic oil under high pressure)!

Wear, damage of the seals, ageing and incorrect mounting of the seal kit by the operator can lead to escapes of oil under high pressure.

- Before using them make a visual control.

Poisoning due to contact with hydraulic oil!

Wear, damage of the seals, ageing and incorrect mounting of the seal kit by the operator can lead to escapes of oil.

Incorrect connection can lead to escapes of oil at the ports.

- For handling with hydraulic oil consider the material safety data sheet.
- Wear protection equipment.

7.1 Design

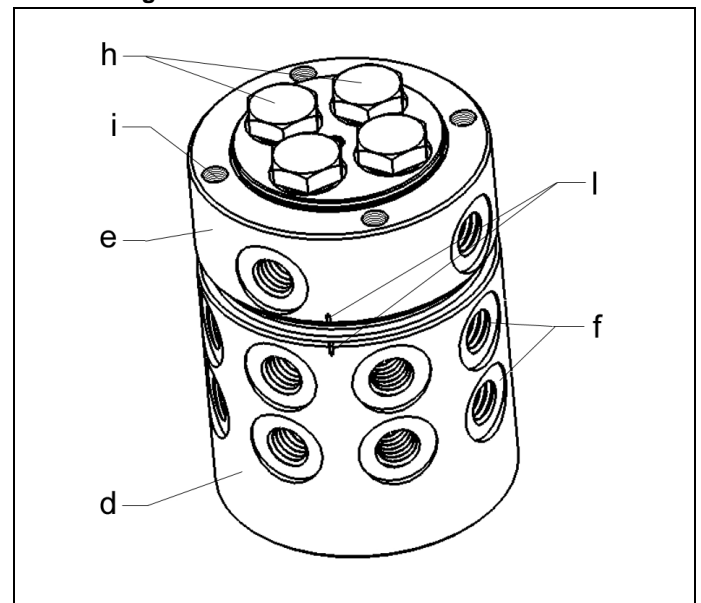

Figure 1: Components and accessories

d	Housing of rotary coupling	h	Ports optionally axial or radial
e	Rotary piston	i	Threaded holes for fixing
f	Hydraulic ports radial	l	Marking (notches) at the housing and the piston

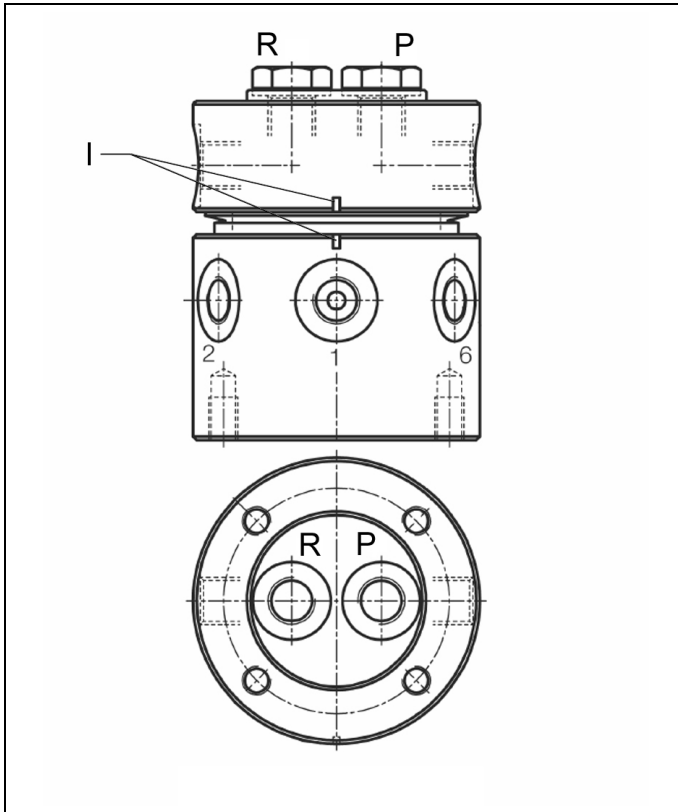

Figure 2: Example rotary coupling for 6 stations

R Port for oil return	I Marking (notches) at the housing and the piston
P Port for continuous clamping pressure	

Example for rotary valve coupling with single-acting cylinders

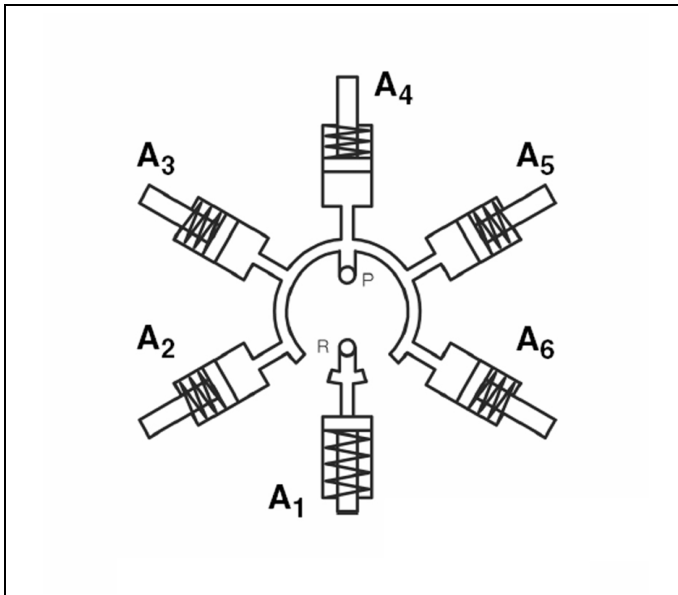

Figure 3: Example for rotary valve coupling with single-acting cylinders

A1 Port for loading and unloading station	B1 to Bn (according to the version) port for consumer elements
A1 to An Port for consumer elements	Unclamping
Clamping	

7.2 Installation and connecting possibilities

⚠ CAUTION

Material damage

- All passages must be pressurised with oil, otherwise wear can be increased.
- Unused ports must be tightly sealed with fittings to avoid the penetration of dirt.

ℹ NOTE

- Fix rotary couplings only through the provided bore holes.
- An anti-rotation key must be mounted. It must be observed that no deformation will be introduced to the rotary coupling (see figure installation examples).

Fixing is made at the housing or at the flange of the rotary piston. It does not matter which component rotates or stands still.

It is important that the component has sufficient freedom of motion so that there will not be any forced conditions.

The screw-on or flange-mounting surface must be flat and square to the axis of rotation.

The transmission of the torque is made by an anti-rotation key that gives sufficient freedom of motion in case of unavoidable misalignments. If the direction of rotation changes, the clearance should not be larger than required.

Installation example for multi-passage rotary couplings:

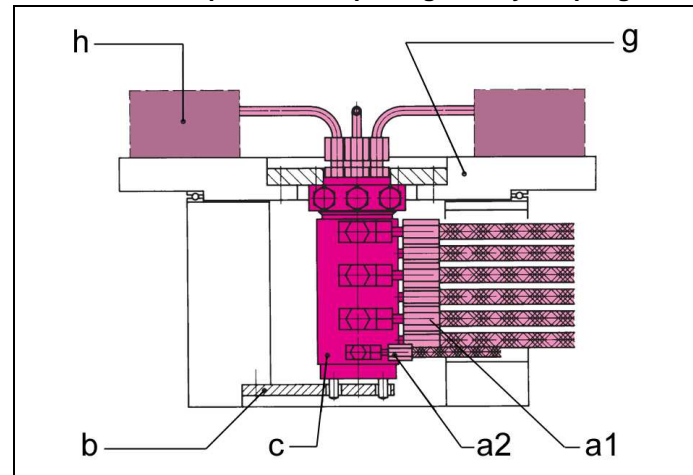

Figure 4: Installation and connecting possibilities

a1 Elbow coupling, hydraulic port	c Rotary coupling
a2 Angle swivel joint, leakage port	g Rotary table
b Anti-rotation key	h Fixture

Compensation of moments with minimum deformation:

Installation example for compensation of moments with minimum deformation at the rotary piston. Supply hydraulic oil or air through hoses.

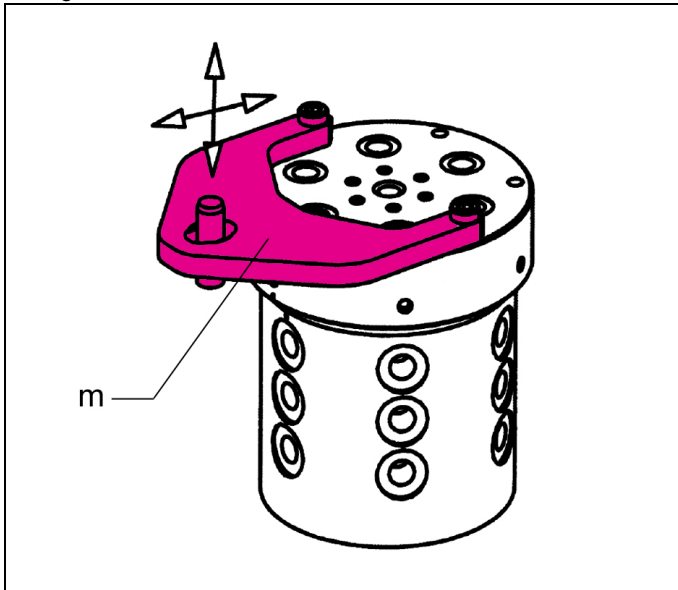

Figure 5: Installation and connecting possibilities

m	Compensation of moments with screws (customer's accessory)
---	--

NOTE

- All figures are schematic figures.

7.3 Connection of the hydraulic equipment

The flange-mounted component of the rotary coupling is connected with pipes.

The other component must be connected with high-pressure hoses. There are two reasons:

- Despite of the anti-rotation key forced conditions would be generated by the piping, i.e. the pipes would generate torsional stress and bending stress. The safety of pipe connections would not be guaranteed.
- Because of the pipe lines side loads would be introduced into the bearing of the rotary piston, and this can lead to a reduced service life.

For safety reasons a fork-shaped anti-rotation key should be used (see fig. installation and connecting possibilities) to fix the housing at the wrench flat. The connection of high-pressure hoses has to be preferred in any case to relieve the fittings.

8 Start up

- Check tight seating (check tightening torque of the fixing screws, see chapter "Technical characteristics").
- Check tight seating of hydraulic connections (check tightening torque of the hydraulic connections, see chapter "Technical characteristics").
- Bleed the hydraulic system.

NOTE

Important

- Before the first start up, pay attention to the increased torque - "breakaway torque"!
- The breakaway torque can be twice the indicated torque (technical characteristics).

NOTE

- For start up of rotary valve couplings the markings (notches) at the housing and the piston have to coincide, than A1 or A1/B1 is the loading and unloading station.

8.1 Operation

Safe operation

- Rotate rotary coupling only, if all passages are pressurised with oil, do not operate dry.
- Insert filter for continuous functioning.
- Swarf or contamination in the hydraulic oil lead to increased wear or damage at the guides, running surfaces and seals.
- Use hydraulic oil as per ROEMHELD data sheet A 0.100.
- Pay attention to the indication for filtration and purity class of the hydraulic fluid.

9 Maintenance

WARNING

Burning due to hot surface!

- In operating conditions, surface temperatures of more than 70 °C can appear at the product.
- All maintenance and repair works must only be effected in cooled mode or with safety gloves.

9.1 Plan for maintenance

Maintenance works	Interval	Realisation
Cleaning	As required	Operator
Regular checks	daily	Operator
Repair/ change seal kit	1,000,000 cycles or 2 years	Qualified personnel

9.2 Cleaning

CAUTION

Avoid damages of the moved components

Avoid damages of the moved components (rods, plungers, bolts, etc.) as well as of wiper and seal.

Aggressive cleaning agents

The product must not be cleaned with:

- Corrosive or corroding components or
- Organic solvents as halogen or aromatic hydrocarbons and ketones (cellulose thinner, acetone, etc.), because this can destroy the seals.

The product must be cleaned from dirt, swarf and liquids at regular intervals.

In the case of heavy contamination, the cleaning has to be made in shorter intervals.

9.3 Regular checks

1. Check tightness of hydraulic connections (visual control).
2. Check components if there are damages.
3. Leakage control at the housing and the rotary piston.
5. Check the observance of the maintenance intervals.

9.4 Exchange seal kit

The exchange of the seal kit is made in case of external leakages. For high availability, the seals have to be changed at the latest after 1,000,000 cycles or 2 years.

The seal kit is available as spare part. An instruction for the exchange of the seal kit is available on request.

i NOTE

Seal Kits

- Do not install seal kits which were exposed to light for a longer time.
- Pay attention to the storage conditions (see chapter "Technical characteristics").
- Only use original seals.

Mounting instructions for seals

- Pay attention to the general mounting instructions for seals, S 0.001.

10 Trouble shooting

Trouble	Cause	Remedy
Rotary piston does not rotate, or sluggish	Rotary (valve) coupling installed with deformation	Correct installation situation
	no hydraulic oil pressurised	Pressurise all passages with oil pressure
Oil loss / pressure loss	Return line contaminated	Clean return line
	Wear	Return for repair
	Rotary (valve) coupling installed with deformation	Check installation situation
Loss of leakage oil higher than admissible leakage rate	Sealing worn	Return for repair
Switching function incorrect	Wrong allocation of ports	Check allocation of ports
Pressure drop in the system	Sealing worn	Return for repair
	Rotary (valve) coupling installed with deformation	Correct installation situation

11 Technical characteristics

Type	Maximum operating pressure [bar]	Adm. torque [Nm] at P max. *) [min ⁻¹]	Max. flow rate [l / min]	Weight [kg]
9208 176	10 bis 500	10	8	0,18
9208 069				0,12
9281 136	100 bis 500	50	12	2,40
9281 135				2,75
9284 036	100 bis 500	25	12	4,60
9284 135				5,50
9286 135	10 bis 500	25	12	7,20

*) Max. admissible number of rotations n and starting torque M as a function of the operating pressure p see data sheet.

Proposal, tightening torques for screws of tensile strength 8.8, 10.9, 12.9

i NOTE

The indicated values are approximate values and have to be interpreted according to the user's application!

See note!

Thread	Tightening torque [Nm]		
	8.8	10.9	12.9
M6	10	15	18
M8	25	36	45
M10	49	72	84
M12	85	125	145
M14	135	200	235
M16	210	310	365
M20	425	610	710
M24	730	1050	1220
M30	1,450	2100	2450

Note: Valid for workpieces and set screws made of steel with metric thread and connecting surface dimensions as per DIN 912, 931, 933, 934 / ISO 4762, 4014, 4017, 4032

In the table values for tightening torques the following is considered:

Design steel/steel, friction value $\mu_{ges} = 0.14$ - not oiled, utilisation of the minimum yield point = 90%.

i NOTE

Further information

- For further technical data see ROEMHELD data sheet.

12 Accessory

i NOTE

Accessories

- See data sheet.

13 Storage

CAUTION

Storage of components!

- The product may not be exposed to direct solar radiation, because the UV light can destroy the seals.
- A storage differing from the storage conditions is inadmissible.
- In case of improper storage, the seals can embrittle and resinification of the anti-corrosive oil or corrosion at the element can occur.

The elements are tested by default with mineral oil. The exterior of the elements is treated with a corrosion inhibitor.

The oil film remaining after the test provides for a six-month interior corrosion protection, if stored in dry and uniformly tempered rooms.

For longer storage times, the element has to be filled with a non-resinifying corrosion inhibitor and the outside surfaces must be treated.

14 Disposal



Hazardous to the environment

Due to possible environmental pollution, the individual components must be disposed only by an authorised expert company.

The individual materials have to be disposed as per the existing regulations and directives as well as the environmental conditions.

Special attention has to be drawn to the disposal of components with residual portions of hydraulic fluids. The instructions for the disposal at the material safety data sheet have to be considered.

For the disposal of electrical and electronic components (e.g. stroke measuring systems, proximity switches, etc.) country-specific legal regulations and specifications have to be kept.

15 Declaration of manufacture

Manufacturer

Römheld GmbH Friedrichshütte
Römheldstraße 1-5
35321 Laubach, Germany
Tel.: +49 (0) 64 05 / 89-0
Fax: +49 (0) 64 05 / 89-211
E-mail: info@roemheld.de
www.roemheld.com

Declaration of manufacture of the products

Rotary valve couplings of the data sheet F 9.290. The following types or part numbers are concerned:

Loading and unloading in one station:

- 9295 001, 002 number of stations 5
 - 9296 001, 002 number of stations 6
 - 9297 001, 002 number of stations 7
 - 9298 001, 002 number of stations 8
 - 9299 001, 002 number of stations 9
 - 9290 001, 002 number of stations 10
- 001 single-acting cylinders
002 double-acting cylinders

Loading and unloading in two stations - commonly controlled:

- 9396 011, 012 number of stations 6
 - 9298 011, 012 number of stations 8
 - 9290 011, 012 number of stations 10
- 011 single-acting cylinders
012 double-acting cylinders

Loading and unloading in two stations - separately controlled:

- 9296 101, 102 number of stations 6
 - 9298 101, 102 number of stations 8
 - 9290 101, 102 number of stations 10
- 101 single-acting cylinders
102 double-acting cylinders

They are designed and manufactured in line with the relevant versions of the directives **2006/42/EC** (EC MSRL) and in compliance with the valid technical rules and standards. In accordance with EC-MSRL and EN 982, these products are components that are not yet ready for use and are exclusively designed for the installation in a machine, a fixture or a plant.

According to the pressure equipment directives the products are not to be classified as pressure reservoirs but as hydraulic placing devices, since pressure is not the essential factor for the design, but the strength, the inherent stability and solidity with regard to static or dynamic operating stress.

The products may only be put into operation after it was assessed that the incomplete machine/machine, in which the product shall be installed, corresponds to the machinery directives (2006/42/EC).

The manufacturer commits to transmit the special documents of the products to state authorities on request. The technical documentation as per appendix VII part B was prepared for the products.

Responsible person for the documentation:
Dipl.-Ing. (FH) Jürgen Niesner, Tel.: +49(0)6405 89-0.

Römheld GmbH
Friedrichshütte
www.roemheld.com, 04.02.2014