



## Swing Clamps with Sturdy Swing Mechanism

Top flange type, with optional position monitoring, double acting, max. operating pressure 350 bar



### 1 Description of the product

The hydraulic swing clamp is a pull-type cylinder where a part of the total stroke is used to swing the piston.

The favourable area ratio (piston/piston rod) allows high clamping forces already at relatively low oil pressures.

Due to the sturdy swing mechanism the angle position of the clamping arm remains the same after a slight collision with the workpiece during loading or unloading. Also a collision during the clamping process is not critical.

When using high flow rates the swing speed is limited by installed throttle points.

The FKM wiper at the piston rod can be protected against rough and hot swarf by an optionally available metallic wiper.

### Table of contents

1	Description of the product	1
2	Validity of the documentation	2
3	Target group of this document	2
4	Symbols and signal words	2
5	For your safety	3
6	Application	3
7	Installation	4
8	Start up	8
9	Maintenance	11
10	Trouble shooting	12
11	Technical characteristics	12
12	Storage	12
13	Accessory	13
14	Position monitoring	13
15	Disposal	13
16	Declaration of manufacture	13

## 2 Validity of the documentation

This document applies to the following products:

Swing clamps with sturdy swing mechanism of data sheet B 1.853. The following types or part numbers are concerned:

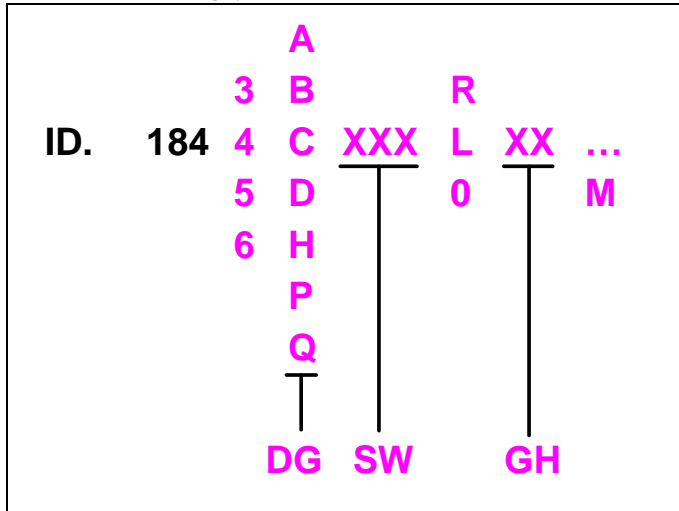

Figure 1: Code for part numbers

SW = Swing angle [°] DG = Version	GH = Total stroke [mm]
--------------------------------------	------------------------

Size	DG = Version
3 Ø23 / Ø16	A Without monitoring
4 Ø28 / Ø20	B With switch rod
5 Ø36 / Ø25	C With pneumatic valve, monitoring clamped 2...9 mm
6 Ø45 / Ø32	D With orifice plate, monitoring unclamped
	H Combination of C + D
	P With pneumatic valve, monitoring clamped 2...10 mm
	Q Combination of P+D
<b>Swing direction</b>	
R Swing direction clockwise	
L Swing direction counter-clockwise	
0 Without, 0 degree	
<b>Metallic wiper</b>	
... without metallic wiper	
M Metallic wiper	

## 3 Target group of this document

- Specialists, fitters and set-up men of machines and installations with hydraulic expert knowledge.

### Qualification of the personnel

**Expert knowledge** means that the personnel must

- be in the position to read and completely understand technical specifications such as circuit diagrams and product-specific drawing documents,
- have expert knowledge (electric, hydraulic, pneumatic knowledge, etc.) of function and design of the corresponding components.

An **expert** is somebody who has due to its professional education and experiences sufficient knowledge and is familiar with the relevant regulations so that he

- can judge the entrusted works,
- can recognize the possible dangers,
- can take the required measures to eliminate dangers,
- knows the acknowledged standards, rules and guidelines of the technology.
- has the required knowledge for repair and mounting.

## 4 Symbols and signal words

### **WARNING**

#### Person damage

Stands for a possibly dangerous situation.

If it is not avoided, death or very severe injuries will result.

### **CAUTION**

#### Easy injuries / property damage

Stands for a possibly dangerous situation.

If it is not avoided, minor injuries or material damages will result.



#### **Hazardous to the environment**

The symbol stands for important information for the proper handling with materials that are hazardous to the environment.

Ignoring these notes can lead to heavy damages to the environment.

### **Note**

This symbol stands for tips for users or especially useful information. This is no signal word for a dangerous or harmful situation.

## 5 For your safety

### 5.1 Basic information

The operating instructions serve for information and avoidance of dangers when installing the products into the machine as well as information and references for transport, storage and maintenance.

Only in strict compliance with these operating instructions, accidents and property damages can be avoided as well as trouble-free operation of the products can be guaranteed.

Furthermore, the consideration of the operating instructions will:

- avoid injuries
- reduce down times and repair costs,
- increase the service life of the products.

### 5.2 Safety instructions

The product was manufactured in accordance with the generally accepted rules of the technology.

Observe the safety instructions and the operating instructions given in this manual, in order to avoid personal damage or material damage.

- Read these operating instructions thoroughly and completely, before you work with the product.
  - Keep these operating instructions so that they are accessible to all users at any time.
  - Pay attention to the current safety regulations, regulations for accident prevention and environmental protection of the country in which the product will be used.
  - Use the ROEMHELD product only in perfect technical condition.
  - Observe all notes on the product.
  - Use only accessories and spare parts approved by the manufacturer in order to exclude danger to persons because of not suited spare parts.
  - Respect the intended use.
- 
- You only may start up the product, when it has been found that the incomplete machine or machine, in which the product shall be mounted, corresponds to the country-specific provisions, safety regulations and standards.
  - Perform a risk analysis for the incomplete machine, or the machine.
 

Due to the interactions between the product and the machine/fixture or the environment, risks may arise that only can be determined and minimized by the user, e.g. :

    - generated forces,
    - generated movements,
    - Influence of hydraulic and electrical control,
    - etc.

## 6 Application

### 6.1 Intended use

The products are designed exclusively for clamping of work-pieces or as a swivelling stop in industrial applications. They must only be operated with hydraulic oil.

Furthermore the following belongs to possible uses:

- Use within the capacity indicated in the technical characteristics (see data sheet).
- Use as per operating instructions.
- Compliance with service intervals.
- Qualified and trained personnel for the corresponding activities.
- Mounting of spare parts only with the same specifications as the original part.
- Only HLP hydraulic oils may be used.
- Solely clamping arms may be moved.

### 6.2 Misapplication

#### **WARNING**

#### **Injuries, material damages or malfunctions!**

- Do not modify the product!

The use of these products is not admitted:

- For domestic use.
- On pallets or machine tool tables in primary shaping and metal forming machine tools.
- If due to vibrations or other physical / chemical effects damages of the products or seals can be caused.
- In machines, on pallets or machine tool tables that are used to change the characteristics of the material (magnetise, radiation, photochemical procedures, etc.).
- In areas for which special guidelines apply, especially installations and machines:
  - For the use on fun fairs and in leisure parks.
  - In food processing or in areas with special hygiene regulations.
  - For military purposes.
  - In mines.
  - In explosive and aggressive environments (e.g. ATEX).
  - In medical engineering.
  - In the aerospace industry.
  - For passenger transport.
- For other operating and environmental conditions e.g.:
  - Higher operating pressures than indicated on the data sheet or installation drawing.
  - With hydraulic fluids that do not correspond to the specifications.
  - Higher flow rates than indicated on the data sheet or installation drawing.

**Special solutions are available on request!**

## 7 Installation

### ⚠ WARNING

#### Injury by high-pressure injection (squirting out of hydraulic oil under high pressure)!

- Improper connection can lead to escapes of oil under high pressure at the connections.
- Mounting or dismounting of the element must only be made in depressurised mode of the hydraulic system.
- Connection of the hydraulic line as per DIN 3852/ISO 1179.
- Unused connections have to be locked professionally.
- Use all mounting holes.

#### Injury by high-pressure injection (squirting out of hydraulic oil under high pressure)!

Wear, damage of the seals, ageing and incorrect mounting of the seal kit by the operator can lead to escapes of oil under high pressure.

- Before using them make a visual control.

#### Injury by falling parts!

- Keep hands and other parts of the body out of the working area.
- Wear personal protection equipment!

#### Poisoning due to contact with hydraulic oil!

Wear, damage of the seals, ageing and incorrect mounting of the seal kit by the operator can lead to escapes of oil.

Incorrect connection can lead to escapes of oil at the ports.

- For handling with hydraulic oil consider the material safety data sheet.
- Wear protection equipment.

### ⚠ CAUTION

#### Great weight may fall

Some product types have a considerable weight. These have to be secured against working free during transport.

Weight specifications see chapter "Technical characteristics".

## 7.1 Design

This hydraulic clamping element is a pull-type cylinder where a part of the total stroke is used to swing the piston.

Thereby the clamping points are free for loading and unloading of the fixture.

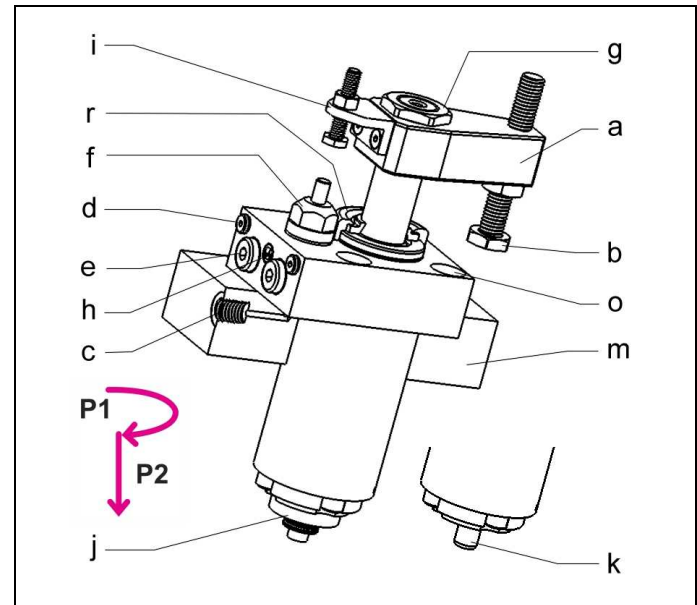

Figure 2: Components dependent on the type

a	Clamping arm (accessory)	g	Fixing nut (included in the delivery)
b	Contact bolt (accessory)	h	Silencer
c	Hydraulic or pneumatic ports in the fixture (positions see data sheet)	i	Angle complete
d	Screw plugs pneumatic position monitoring S = Clamping position E = Unclamping position	j	Orifice plate for monitoring unclamped
e	Hydraulic port A = Clamping B = Unclamping	k	Extended switch rod
f	Piston with integrated swing mechanism	m	Fixture body with plug-in geometry (see data sheet)
		o	Fixing holes
		P1	Swing stroke
		P2	Clamping stroke
		r	Metallic wiper (optional)

## 7.2 Installation and connecting possibilities

The following installation and connecting options are possible

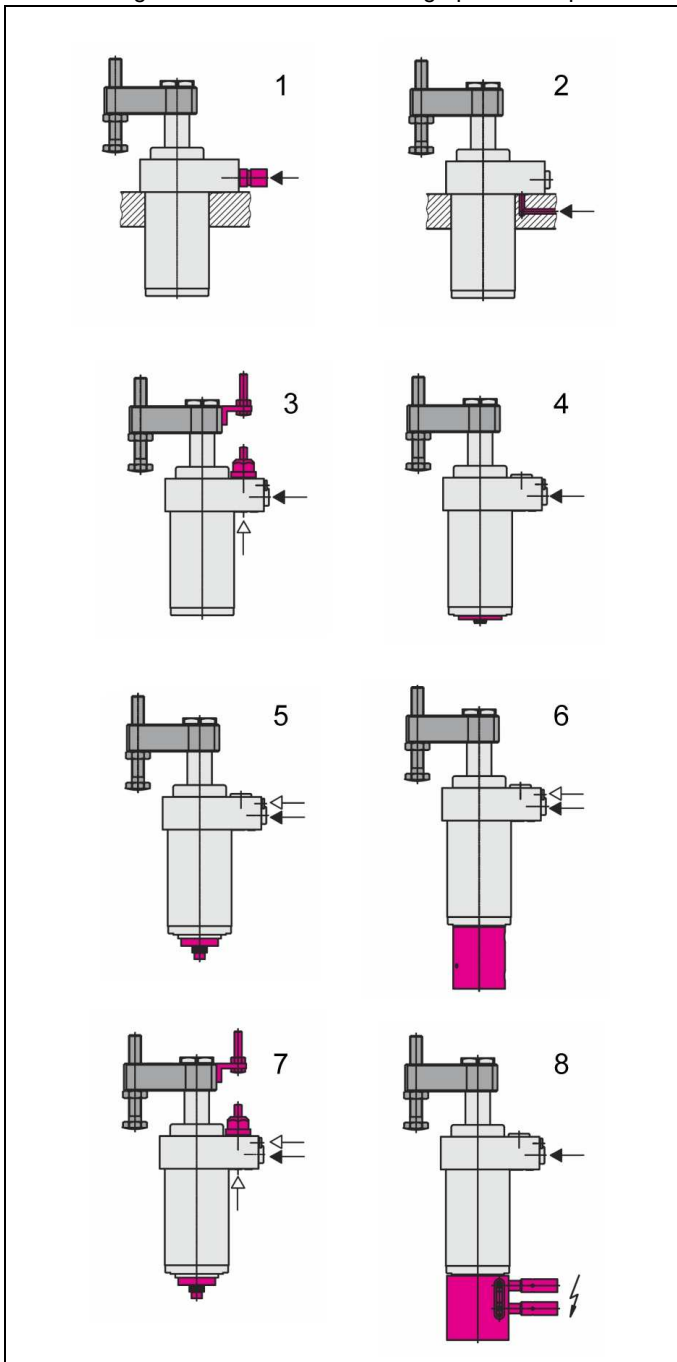

Figure 3: Installation and connecting possibilities

1 Version 184XA... Connection by pipe thread	5 Version 184XD... Monitoring of unclamping position by control disk
2 Version 184XA... Connection through drilled channels	6 Version 184XB... Monitoring of clamping and unclamping position by pneumatic position monitoring (accessory)
3 Version 184XC...& 184XP... Monitoring of the clamping position via an integrated pneumatic valve and angle with adjusting screw	7 Version 184XH...(C+D) / 184XQ...(P+D)... Monitoring of clamping and unclamping position by combination.
4 Version 184XB... with extended piston rod for control by position monitoring (see accessory)	8 Version 184XB... Monitoring of clamping and unclamping position by electrical position monitoring (accessory)

## 7.3 Swing angle and direction

The swing clamps are available with swing angles of 0 ° up to 90 °. "Swing direction cw" means clockwise rotation, looking from above onto the piston - from the unclamped to the clamped position.

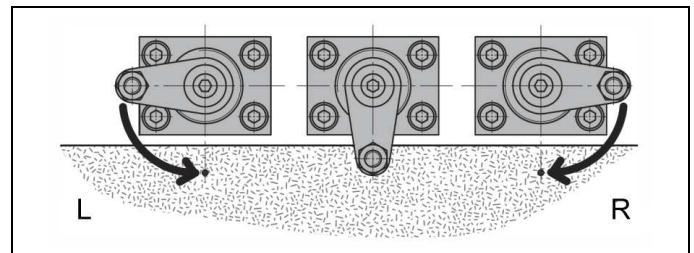

Figure 4: Swing direction  
(L = counterclockwise "ccw", R = clockwise "cw")

## 7.4 Admissible oil flow rate

### **⚠ WARNING**

**Injury due to overload of the element**

**High-pressure injection (squirting out of hydraulic oil under high pressure) or flying components!**

- Due to throttling or closing of ports a pressure intensification can occur.
- Connect the ports professionally!

### **⚠ CAUTION**

**Maximum flow rates do not exceed**

The maximum flow rate must not be exceeded.

### 7.4.1 Calculation of the admissible flow rate

#### Admissible oil flow rate

The admissible flow rate or the admissible stroke speed is valid for vertical mounting positions in combination with standard add-on parts as clamping arms or contact bolts, etc. In case of other mounting positions and/or add-on parts the flow rate has to be reduced.

If the pump flow rate divided by the number of elements is larger than the admissible flow rate of one element, the flow rate has to be throttled.

This prevents an overload and therewith an early failure.

The flow rate can be checked as follows:

$$Q_P \leq 0,06 \cdot \dot{V}_Z \cdot n \text{ and/or } Q_P \leq 6 \cdot v_Z \cdot A_K \cdot n$$

for clamping elements and work supports (indicated on the data sheets)

#### Maximum piston speed

At specified pump flow rate **Q** and with the effective piston area **A** the piston speed can be calculated as follows:

$$v_m < \frac{Q_P}{6 \cdot A_K \cdot n}$$

#### Legend

$\dot{V}_Z$  = Admissible flow rate of the element in [cm<sup>3</sup>/s]

$Q_P$  = Flow rate of the pump in [l/min]

$A_K$  = Piston area in [cm<sup>2</sup>]

$n$  = Number of elements, same dimensions

$v_Z = v_m$  = Admissible/maximum stroke speed in [m/s]

#### NOTE

##### Oil volume

- The maximum oil volume and/or the maximum stroke speed depend on the corresponding product.
  - For clamping cylinders see data sheet A 0.100.
  - or clamping elements, work supports, hydraulic valves, power units and other hydraulic elements indicated on the corresponding data sheets.

Further " things worth knowing about hydraulic cylinders, basics, detailed knowledge and calculations on hydraulic cylinders" see in the [Technical library](#) on the internet!

or download



### 7.4.2 Throttling of the flow rate

The throttling always has to be effected in the supply line to the swing clamp. Only thus pressure intensification and thereby pressures exceeding the operating pressure are avoided. The hydraulic circuit diagram shows flow control valves which allow oil return from the element without any impediments.

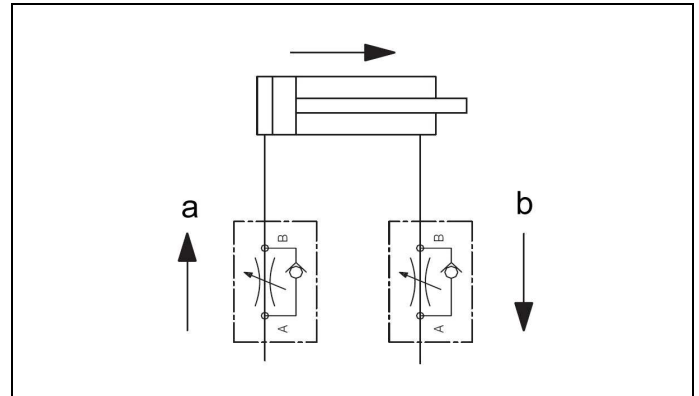

Figure 5: Hydraulic circuit diagram without flow control valves

a Throttling direction	b Free flow
------------------------	-------------

If a return-flow throttling is required due to a negative load, it must be guaranteed that the max. operating pressure (see technical characteristics) will not be exceeded.

### 7.5 Connection of the hydraulic equipment

- Connect hydraulic lines to qualifying standards and pay attention to scrupulous cleanness (A = Extend, B = Retract)!

#### NOTE

##### More details

- See ROEMHELD data sheets A 0.100, F 9.300, F 9.310 and F 9.360.

##### Screwed Plug

- Use only fittings "screwed plug B and E" as per DIN 3852 (ISO 1179).

##### hydraulic connection

- Do not use sealing tape, copper rings or coned fittings.

##### Pressure fluids

- Use hydraulic oil as per ROEMHELD data sheet A 0.100.

## 7.6 Assembly and disassembly of the clamping arm

### **WARNING**

#### Injury by crushing!

Components of the product make a movement while they are in operation.

- This can cause injuries.
- Keep parts of the body and items out of the working area!

### **CAUTION**

#### When tightening and untightening the fixing nut, the piston has to be backed up

- No torques must be introduced into the piston.
- The conical surfaces of the piston and the clamping arm must be clean and grease free!

### **Note**

When tightening and untightening the fixing nut, the clamping arm or the hexagon socket in the piston have to be backed up. It is recommended to effect tightening and untightening in the swing range.

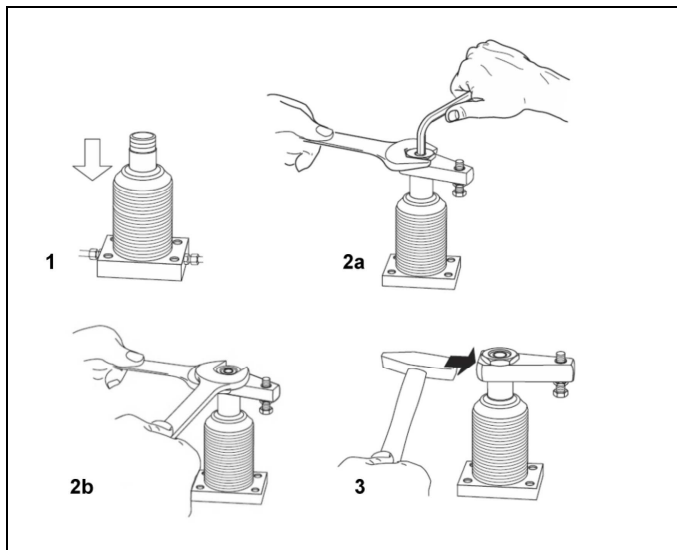

Figure 6: Assembly / disassembly (example)

### 7.6.1 Assembly of the clamping arm - with pressure

1. Retract piston and pressurise clamping line (port A) (Fig. Assembly, **Pos. 1**).
2. Put the clamping arm in the intended clamping position.
3. Fasten fixing nut and hold clamping arm with an Allen key (Tightening torque of the fixing nut for the clamping arm see technical characteristics. Fig. Assembly, **Pos. 2**).
4. Clamp several times.
5. Check if the clamping point is within the clamping stroke (Fig. Adjustment of the clamping arm, **Pos. 2**).

### 7.6.2 Assembly of the clamping arm - without pressure

1. Put the clamping arm onto the piston.
2. Move the piston manually to the clamping position.
3. Align clamping arm.
4. Fasten fixing nut with an Allen key and hold the clamping arm with an open-ended wrench (Tightening torque of the fixing nut for the clamping arm see technical characteristics. Fig. Assembly, **Pos. 2**).
5. Clamp several times.
6. Check if the clamping point is within the clamping stroke (Fig. Adjustment of the clamping arm, **Pos. 2**).

### **NOTE**

#### Tightening torque of the fastening nut

- Tightening torque of the fixing nut for the clamping arm see technical characteristics.

### 7.6.3 Disassembly of the clamping arm - without pressure

### **CAUTION**

#### Piston rod guide

Heavy hammering can destroy the piston rod guide!

1. Loosen the fixing nut one revolution. Hold the clamping arm with an Allen key (**Pos. 2b**).
2. Hammer **slightly** onto the front face to loosen the clamping arm (**Pos. 3**).

## 7.7 Adjustment of contact bolt

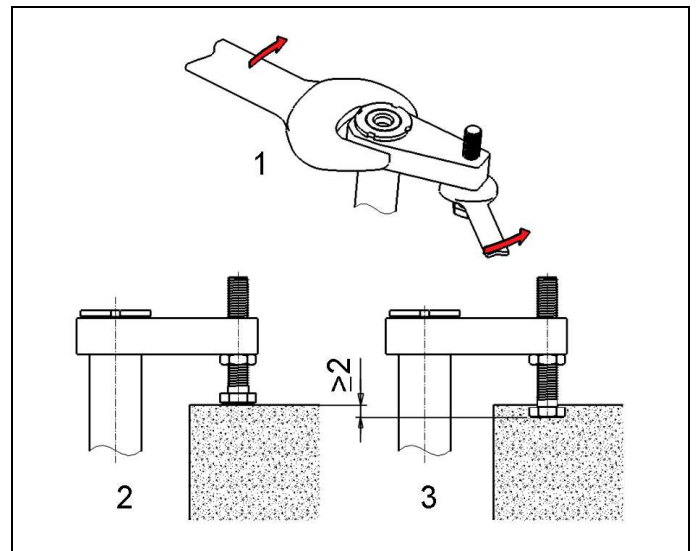

Figure 7: Adjustment of the clamping arm (example)

1. Loosen the lock nut at the contact bolt and completely turn back the contact bolt. (Fig. Adjustment of the clamping arm, **Pos. 1**).
2. Move the clamping arm to the clamping position above the workpiece. (Pay attention to the tolerance of the swing angle)
3. Screw out the contact bolt until it contacts the workpiece. (Fig. Adjustment of the clamping arm, **Pos. 2**).
4. Move the clamping arm back to the unclamping position.
5. Unscrew the contact bolt again by the half of the clamping stroke.

- Tighten the lock nut at the contact bolt. Hold the clamping arm with an open-ended wrench. (Fig. Adjustment of the clamping arm, **Pos. 1**).

### 7.7.1 Check adjustment of the contact bolt

- Move the clamping arm, with throttled flow rate and low pressure to the clamping position onto the workpiece. Pay attention that the contact bolt touches the workpiece only after completion of the swing stroke.
- Measure and note the distance between clamping arm and upper edge of the workpiece in clamped condition (**Pos. 2**).
- Unclamp swing clamp again.
- Unload workpiece out of the fixture.
- Clamp swing clamp again.
- Measure the distance as described below item 2. The distance measured now should be at least 2 mm smaller .

### 7.8 Assembly of the metallic wiper

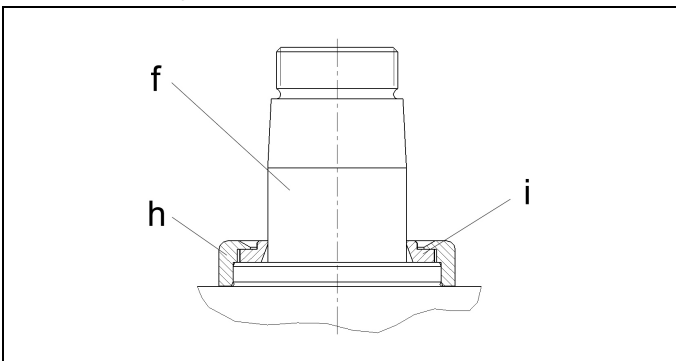

Figure 8: Metallic wiper

f	Piston with integrated swing mechanism	i	Metallic wiper, wiper ring (accessory)
h	Metallic wiper, retaining ring (accessory)		

The swing clamp is optionally supplied with mounted metallic wiper.

The metallic wiper can also be mounted later as an accessory:

- Put the wiper ring onto the piston rod until the ring touches the body, pay attention to smooth running.
- If the wiper ring is too stiff, the hard sealing edge must be ground with emery since otherwise the piston rod will be damaged in the long run.
- Uniformly press the retaining ring without jamming, onto the collar of the body.

## 8 Start up

### ⚠ WARNING

#### Poisoning due to contact with hydraulic oil!

Wear, damage of the seals, ageing and incorrect mounting of the seal kit by the operator can lead to escapes of oil.

Incorrect connection can lead to escapes of oil at the ports.

- For handling with hydraulic oil consider the material safety data sheet.
- Wear protection equipment.

### ⚠ CAUTION

#### Operating pressure of 350 bar does not exceed

The maximum operating pressure of 350 bar must not be exceeded.

- Check tight seating (check tightening torque of the fixing screws, see chapter "Technical characteristics").
- Check tight seating of hydraulic connections (check tightening torque of the hydraulic connections, see chapter "Technical characteristics").
- Bleed the hydraulic system.

### i NOTE

#### Clamping time

- Without bleeding the clamping time will be considerably prolonged and function problems may occur.

- Start up of position monitoring.

### i Note

See operating instructions of the position monitoring.

### 8.1 Bleeding of pipe-mounted types

- Loosen carefully at low pressure union nut of the pipe at the hydraulic ports.
- Pump until bubble free oil comes out.
- Fasten union nuts of the pipe.
- Check tightness.

### 8.2 Bleeding of manifold-mounted types

- Loosen carefully the bleeding screws of the fixture at low pressure.
- Pump until bubble free oil comes out.
- Fasten the bleeding screws.
- Check correct function.
- Check sealing of the hydraulic connections!



### 8.3 Admissible operating pressure

#### **NOTE**

##### Various Clamps

- The swing clamps are designed for a maximum pressure (see chapter Technical characteristics).
- According to the version of the used clamping arm, the operating pressure must be reduced considerably.
- Please pay attention to the clamping force diagrams on the data sheet.

### 8.4 Position monitoring

#### 8.5 Description of position monitorings

##### 8.5.1 Version with switch rod

The switch rod protrudes through the housing and allows thereby a pneumatic or electrical control of the piston position outside the swarf area.

As an accessory a pneumatic position monitoring is available; the brass control slide being displaced in a stainless housing. The slide opens and closes bore holes, so that a pressure switch or a differential pressure switch can signal the position "Clamped" and "Unclamped".

An electrical position monitoring with inductive proximity switches is also available.

See accessory

##### 8.5.2 Version pneumatic valve

If the valve tappet is axially actuated, a control bore is uncovered.

The switching point depends on the existing pneumatic pressure, the flow rate and the used pressure switch or differential pressure switch (recommendations see Technical characteristics).

The switching point can be adjusted.

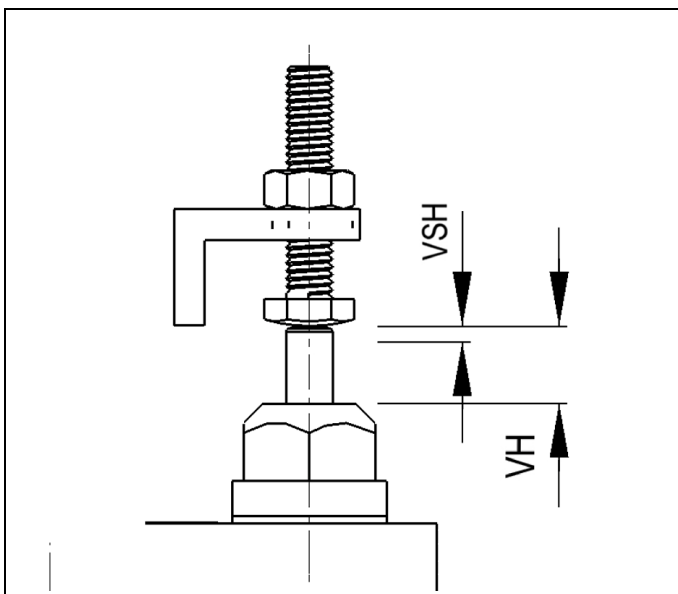

Figure 9: Pneumatic valve

VSH	Stroke until switching	VH	Max. stroke of position monitoring
-----	------------------------	----	------------------------------------

#### **NOTE**

##### Tappet

- No objects may fall on the valve tappet, since otherwise otherwise to damages or malfunctions may occur.

##### 8.5.2.1 Adjustment of position monitoring

#### **CAUTION**

##### Damage of position monitoring

Before adjusting the position monitoring, the contact bolt of the clamping arm must be adjusted.

Otherwise the max. stroke of the position monitoring will be exceeded. This leads to damage of internal parts.

##### Damage of position monitoring

During clamping the clamping arm elastically moves towards the position monitoring. That fact must be taken into account when adjusting the device.

The maximum stroke of the position monitoring should be adjusted to 5 mm.

##### Procedure:

- Loosen the lock nut at the contact bolt of the bracket and completely turn back the contact bolt (dimension 35), so that no damages will be caused during the swing motion.
- Bring swing clamp to clamping position (see chapter Adjustment of contact bolt).
- Unscrew the contact bolt of the bracket until the pneumatic monitoring reacts (see function chart).  
The maximum stroke of the position monitoring should be adjusted to 5 mm.
- Tighten the lock nut at the contact bolt. hold the contact bolt with an open-ended wrench.
- Move the clamping arm back to the unclamping position.
- Check adjustment of the switching point.

##### 8.5.3 Version orifice plate

The orifice plate is pressed by the switch rod against the housing and closes a nozzle.

The switching point **cannot** be adjusted.

#### **NOTE**

The lower part of the swing clamp must be protected against swarf and dirt for trouble-free functioning of the orifice plate.

##### Attention malfunction

If version D or H will be installed in a blind hole, a bleeding possibility must be provided. alternatively port "S" can be used for bleeding.

The depth of the blind hole must be adapted to the retracted length of the switching rod.

## 8.6 Start up

### 8.6.1 Electrical position monitoring

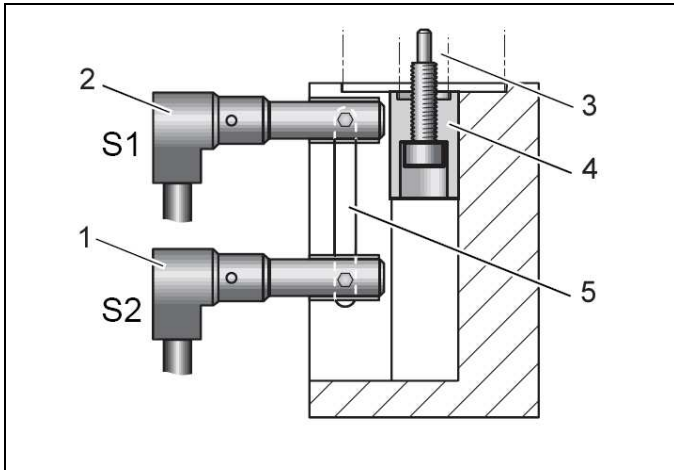

Figure 10: Design of the electrical position monitoring

1 Proximity switch S2 (clamped)	4 Signal sleeve
2 Proximity switch S1 (unclamped)	5 Slot for displacement of the proximity switches
3 Switch rod of the swing clamp	

#### Adjustment of proximity switches

1. Unclamp piston.
2. Screw in proximity switch S1 up to the stop on the signal sleeve and turn back 1/2 rotation.
3. Fix S1 with a headless screw. The distance to the signal sleeve must be 0.5 mm.
4. Displace S1 to the upper stop in the slot. Fix S1 with the socket head cap screw.
5. Clamp piston.
6. Displace S2 in the slot so that a signal course as per figures (Fig. signal course) will be achieved. Fix S2 with the socket head cap screw.

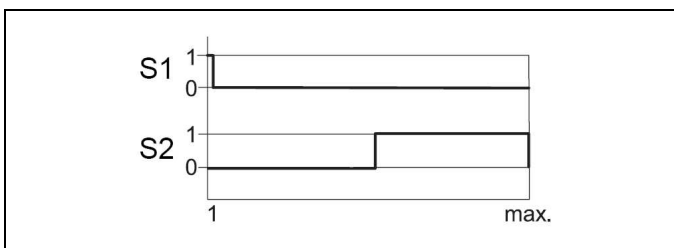

Figure 11: Signal course - clamping

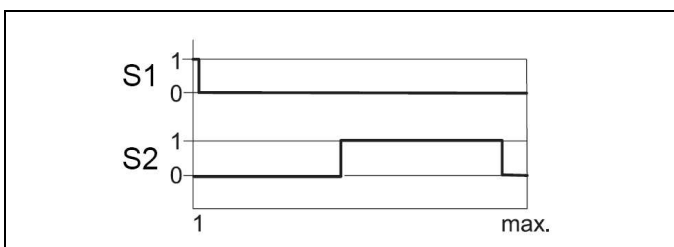

Figure 12: Signal course - unclamping

1 Signal ON	0 Signal OFF
-------------	--------------

The two figures show the signal course at both proximity switches during a clamping and unclamping process (max. = total stroke).

### 8.6.2 Start up

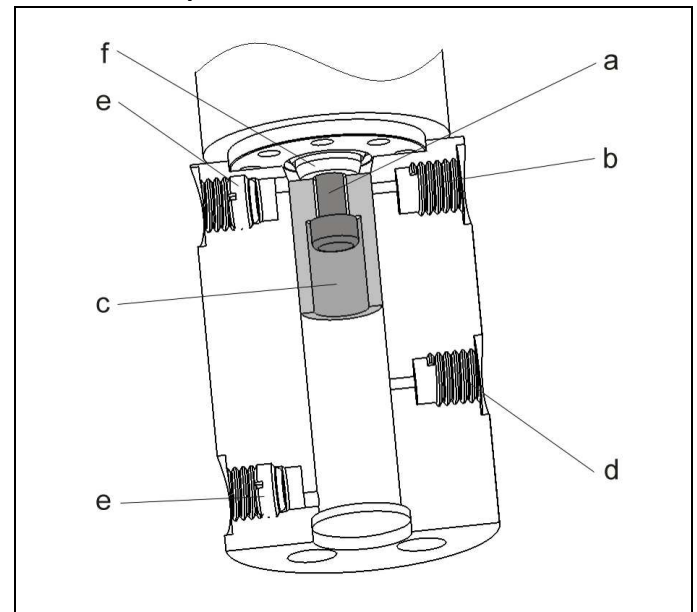

Figure 13: Design

a Fixation of the signal sleeve	d Lower pneumatic port, clamping range
b Upper pneumatic port, unclamped	e Venting by means of the filter element
c Signal sleeve with switching cams	f Switch rod of the swing clamp

1. Connect the pneumatic ports of the differential pressure switch to the position monitoring.
2. The piston position will be signalled by the pressure build up at the upper or lower pneumatic port:

Pressure built-up and/or signal sleeve is	Piston is
at the top (Fig. Design)	extended
at the bottom	retracted

#### **NOTE**

For interpretation of the pneumatic pressure we recommend to use the differential pressure switches type PEL. Series connection for up to 4 swing clamps is possible.

## NOTE

### Evaluation of the pneumatic pressure

- For interpretation of the pneumatic pressure we recommend to use a differential pressure switch.
- Parallel connection for up to 8 elements is possible. For a greater number there are special solutions. Please contact us.

### Evaluation of the pneumatic pressure

- The dependence between pipe length, jet diameter, leakage, pressure and flow rate determines the measurable pressure differential. In case of a too high flow rate the pressure differential is too low.
- For the interpretation of the pneumatic pressure we recommend to use a differential pressure switch. Parallel connection of up to four elements is possible.

### Impurities in the compressed air

- The pollution of the compressed air can lead to interferences in the measurement.

### 8.6.3 Monitoring by pneumatic pressure switch

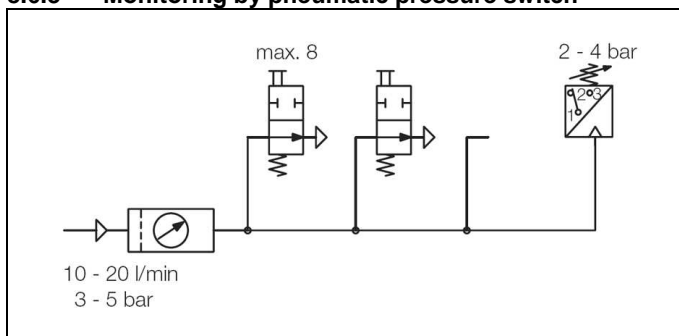

Figure 14: Schematic representation of the monitoring by means of a pressure switch.

For the evaluation of the pneumatic pressure built-up standard pneumatic pressure switches can be used. It is possible to monitor with one pressure switch up to 8 position monitorings connected in series (see circuit diagram).

It has to be considered that process-safe functioning of pneumatic position monitorings is only guaranteed with throttled air and system pressure. The nominal values are indicated below Technical characteristics.

## 9 Maintenance

### WARNING

#### Burning due to hot surface!

- In operating conditions, surface temperatures of more than 70 °C can appear at the product.
- All maintenance and repair works must only be effected in cooled mode or with safety gloves.

## 9.1 Cleaning

### CAUTION

#### Avoid damages of the moved components

Avoid damages of the moved components (rods, plungers, bolts, etc.) as well as of wiper and seal.

#### Aggressive cleaning agents

The product must not be cleaned with:

- Corrosive or corroding components or
- Organic solvents as halogen or aromatic hydrocarbons and ketones (cellulose thinner, acetone, etc.), because this can destroy the seals.

The product must be cleaned at regular intervals, especially the area of the piston or the plunger housing has to be cleaned from swarf and other liquids.

In the case of heavy contamination, cleaning must be made at shorter intervals.

## Note

#### Special care must be taken with:

- dry machining
- minimum quantity lubrication and
- small grinding swarf

Small swarf and dust can stick to the rod / plunger of the element and be pulled into the sealing gap of the metallic wiper edge.

Thus, a sticky / pasty mass of swarf / dust can arise that hardens during standstill.

**Result:** Malfunction due to deadlock / bonding and increased wear.

**Remedy:** Regular cleaning of the piston rod/support plunger in the effective area of the wiper.

## 9.2 Regular checks

1. Check tightness of hydraulic connections (visual control).
2. Check running surfaces (of the piston rod or bolt) if there are marks and scratches. Traces of marks can be an indication for a contaminated hydraulic system or an inadmissible side load of the block cylinder.
3. Leakage check at the housing - piston rod, bolt or flange.
4. Clamping force control by pressure control.
5. Check if the maintenance intervals are kept.

## 9.3 Exchange seal kit

The exchange of the seal kit is made in case of external leakages. For high availability, the seals have to be changed at the latest after 500,000 cycles or 2 years.

The seal kit is available as spare part. An instruction for the exchange of the seal kit is available on request.

## NOTE

#### Seal Kits

- Do not install seal kits which were exposed to light for a longer time.
- Pay attention to the storage conditions (see chapter "Technical characteristics").
- Only use original seals.

## 10 Trouble shooting

Trouble	Cause	Remedy
Piston rod with clamping arm does not retract	Clamping pressure is not available or too low	Check at the pressure generator, if pressure is available and high enough (minimum pressure: 30 bar)
Swing angle is not completely effected or exceeded (tolerance of end position $\pm 2^\circ$ ):	Too much clearance in the swing mechanism	<b>⚠ Caution !</b> Repair required by ROEMHELD
	Operating pressure too low	Adjust operating pressure in accordance with the technical characteristics.
Piston rod has too much play:	Guide or piston rod are worn out	Exchange piston rod, exchange component, if required
Clamping pressure reduces due to leakages at the swing clamp:	Wear at the seals	Exchange seals

Trouble	Cause	Remedy
Piston rod with clamping arm does not retract	Clamping pressure is not available or too low	Check at the pressure generator, if pressure is available and high enough (minimum pressure: 30 bar)
Swing angle is not completely effected or exceeded (tolerance of end position $\pm 2^\circ$ ):	Too much clearance in the swing mechanism	<b>⚠ Caution!</b> Repair required by ROEMHELD
	Operating pressure too low	Adjust operating pressure in accordance with the technical characteristics.
Piston rod has too much play:	Guide or piston rod are worn out	Exchange piston rod, exchange component, if required
Clamping pressure reduces due to leakages at the swing clamp:	Wear at the seals	Exchange seals

## 11 Technical characteristics

### General characteristics

Types	Maximum operating pressure	Max. effective clamping force
	[bar]	[kN]
(as a function of the clamping arm length, see diagrams - data sheet)		
1843 XXX X23 X	350	<b>5.7</b>
1844 XXX X23 X		<b>8.0</b>
1845 XXX X23 X		<b>14.0</b>
1846 XXX X23 X		<b>20.0</b>

Types	Thread sizes	Tightening torque of the fixing nut of the clamping arm [Nm]
1843-XXX	M14 x 1.5	<b>16</b>
1844-XXX	M18 x 1.5	<b>30</b>
1845-XXX	M20 x 1.5	<b>42</b>
1846-XXX	M28 x 1.5	<b>90</b>

### Weights

Types	Total stroke	Weight
	[mm]	[kg]
1843 XXX X23 X	23	<b>1.7</b>
1844 XXX X23 X	24	<b>2.3</b>
1845 XXX X23 X	30	<b>3.9</b>
1846 XXX X23 X	36	<b>6.0</b>

## 12 Storage

### **⚠ CAUTION**

#### Storage of components!

- The product may not be exposed to direct solar radiation, because the UV light can destroy the seals.
- A storage differing from the storage conditions is inadmissible.
- In case of improper storage, the seals can embrittle and resinification of the anti-corrosive oil or corrosion at the element can occur.

The elements are tested by default with mineral oil. The exterior of the elements is treated with a corrosion inhibitor.

The oil film remaining after the test provides for a six-month interior corrosion protection, if stored in dry and uniformly tempered rooms.

For longer storage times, the element has to be filled with a non-resinifying corrosion inhibitor and the outside surfaces must be treated.

## 13 Accessory

### 13.1 Selection of the clamping arm

#### **CAUTION**

##### Using an incorrect clamping arm

When using incorrect clamping arms, damages can occur.

When selecting the clamping arm, the corresponding operating pressures as shown in the clamping force diagram (see ROEMHELD data sheet) must not be exceeded. If longer clamping arms will be used, not only the operating pressure but also the flow rate has to be reduced.

## 14 Position monitoring

- Position monitoring

#### **NOTE**

- See ROEMHELD data sheet.

## 15 Disposal



##### Hazardous to the environment

Due to possible environmental pollution, the individual components must be disposed only by an authorised expert company.

The individual materials have to be disposed as per the existing regulations and directives as well as the environmental conditions.

Special attention has to be drawn to the disposal of components with residual portions of hydraulic fluids. The instructions for the disposal at the material safety data sheet have to be considered.

For the disposal of electrical and electronic components (e.g. stroke measuring systems, proximity switches, etc.) country-specific legal regulations and specifications have to be kept.

## 16 Declaration of manufacture

### Manufacturer

Römheld GmbH Friedrichshütte  
Römheldstraße 1-5  
35321 Laubach, Germany  
Tel.: +49 (0) 64 05 / 89-0  
Fax: +49 (0) 64 05 / 89-211  
E-mail: info@roemheld.de  
www.roemheld.com

### Declaration of manufacture of the products

Swing clamps with sturdy swing mechanism of data sheet B 1.853. The following types or part numbers are concerned:

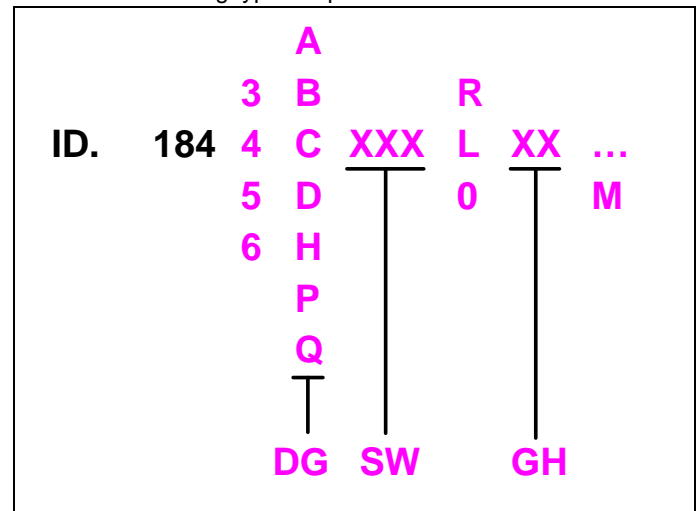

Figure 15: Code for part numbers

SW = Swing angle [°]	GH = Total stroke [mm]
DG = Version	

They are designed and manufactured in line with the relevant versions of the directives **2006/42/EC** (EC MSRL) and in compliance with the valid technical rules and standards. In accordance with EC-MSRL and EN 982, these products are components that are not yet ready for use and are exclusively designed for the installation in a machine, a fixture or a plant.

According to the pressure equipment directives the products are not to be classified as pressure reservoirs but as hydraulic placing devices, since pressure is not the essential factor for the design, but the strength, the inherent stability and solidity with regard to static or dynamic operating stress.

The products may only be put into operation after it was assessed that the incomplete machine/machine, in which the product shall be installed, corresponds to the machinery directives (2006/42/EC).

The manufacturer commits to transmit the special documents of the products to state authorities on request. The technical documentation as per appendix VII part B was prepared for the products.

Responsible person for the documentation:  
Dipl.-Ing. (FH) Jürgen Niesner, Tel.: +49(0)6405 89-0.

**Römheld GmbH**  
**Friedrichshütte**  
Laubach, 30.01.2014