

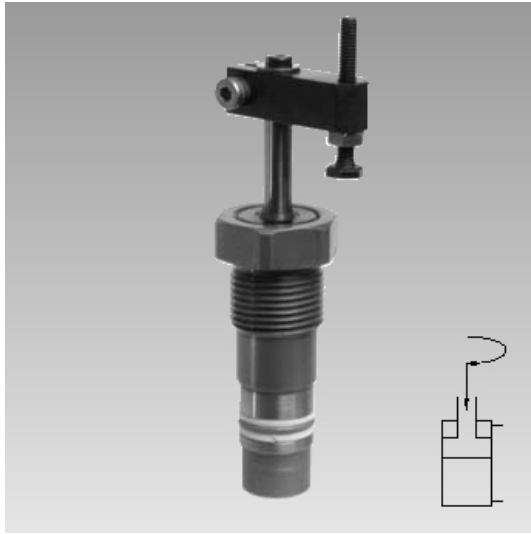

## Mini swing clamps

threaded-body type, double acting, max. operating pressure 150 bar



### Table of contents

1	Description of the product	1
2	Validity of the documentation	1
3	Target group of this document	1
4	Symbols and signal words	2
5	For your safety	2
6	Application	2
7	Transport	3
8	Installation	3
9	Start up	7
10	Maintenance	8
11	Trouble shooting	8
12	Technical characteristics	9
13	Accessory	9
14	Storage	9
15	Disposal	10
16	Declaration of manufacture	10

### 1 Description of the product

Double-acting mini swing clamps as a threaded-body version. The most important characteristics are as follows:

- FKM wiper  
This wiper has a high chemical resistance when using aggressive cutting fluids.
- Omission of the overload protection device  
In the case of a slight collision with the clamping arm during loading and unloading of the fixture, the angular position of the clamping arm will be maintained. Less critical are the weight of the clamping arm or an increased swing speed.

### 2 Validity of the documentation

This document applies to the following products:

Mini swing clamps of data sheet B 1.848.

The following types or part numbers are concerned:

- 1848-105, -115, -125, -135, -145, -155, -165

### 3 Target group of this document

- Specialists, fitters and set-up men of machines and installations with hydraulic expert knowledge.

#### Qualification of the personnel

**Expert knowledge** means that the personnel must

- be in the position to read and completely understand technical specifications such as circuit diagrams and product-specific drawing documents,
- have expert knowledge (electric, hydraulic, pneumatic knowledge, etc.) of function and design of the corresponding components.

An **expert** is somebody who has due to its professional education and experiences sufficient knowledge and is familiar with the relevant regulations so that he

- can judge the entrusted works,
- can recognize the possible dangers,
- can take the required measures to eliminate dangers,
- knows the acknowledged standards, rules and guidelines of the technology.
- has the required knowledge for repair and mounting.

## 4 Symbols and signal words

### **WARNING**

#### Person damage

Stands for a possibly dangerous situation.

If it is not avoided, death or very severe injuries will result.

### **CAUTION**

#### Easy injuries / property damage

Stands for a possibly dangerous situation.

If it is not avoided, minor injuries or material damages will result.

#### Hazardous to the environment

The symbol stands for important information for the proper handling with materials that are hazardous to the environment.

Ignoring these notes can lead to heavy damages to the environment.



#### Mandatory sign!

The symbol stands for important information, necessary protection equipment, etc.

### **NOTE**

- This symbol stands for tips for users or especially useful information. This is no signal word for a dangerous or harmful situation.

## 5 For your safety

### 5.1 Basic information

The operating instructions serve for information and avoidance of dangers when installing the products into the machine as well as information and references for transport, storage and maintenance.

Only in strict compliance with these operating instructions, accidents and property damages can be avoided as well as trouble-free operation of the products can be guaranteed.

Furthermore, the consideration of the operating instructions will:

- avoid injuries
- reduce down times and repair costs,
- increase the service life of the products.

### 5.2 Safety instructions

The product was manufactured in accordance with the generally accepted rules of the technology.

Observe the safety instructions and the operating instructions given in this manual, in order to avoid personal damage or material damage.

- Read these operating instructions thoroughly and completely, before you work with the product.
- Keep these operating instructions so that they are accessible to all users at any time.
- Pay attention to the current safety regulations, regulations for accident prevention and environmental protection of the country in which the product will be used.
- Use the ROEMHELD product only in perfect technical condition.
- Observe all notes on the product.
- Use only accessories and spare parts approved by the manufacturer in order to exclude danger to persons because of not suited spare parts.
- Respect the intended use.

- You only may start up the product, when it has been found that the incomplete machine or machine, in which the product shall be mounted, corresponds to the country-specific provisions, safety regulations and standards.
- Perform a risk analysis for the incomplete machine, or the machine.

Due to the interactions between the product and the machine/fixture or the environment, risks may arise that only can be determined and minimized by the user, e.g. :

- generated forces,
- generated movements,
- Influence of hydraulic and electrical control,
- etc.

## 6 Application

### 6.1 Intended use

The products are designed exclusively for clamping of workpieces or as a swivelling stop in industrial applications. They must only be operated with hydraulic oil.

Furthermore the following belongs to possible uses:

- Use within the capacity indicated in the technical characteristics (see data sheet).
- Use as per operating instructions.
- Compliance with service intervals.
- Qualified and trained personnel for the corresponding activities.
- Mounting of spare parts only with the same specifications as the original part.
- Only HLP hydraulic oils may be used.
- Solely clamping arms may be moved.

## 6.2 Misapplication

### **⚠ WARNING**

#### Injuries, material damages or malfunctions!

- Do not modify the product!

The use of these products is not admitted:

- For domestic use.
- On pallets or machine tool tables in primary shaping and metal forming machine tools.
- If due to vibrations or other physical / chemical effects damages of the products or seals can be caused.
- In machines, on pallets or machine tool tables that are used to change the characteristics of the material (magnetise, radiation, photochemical procedures, etc.).
- In areas for which special guidelines apply, especially installations and machines:
  - For the use on fun fairs and in leisure parks.
  - In food processing or in areas with special hygiene regulations.
  - For military purposes.
  - In mines.
  - In explosive and aggressive environments (e.g. ATEX).
  - In medical engineering.
  - In the aerospace industry.
  - For passenger transport.
- For other operating and environmental conditions e.g.:
  - Higher operating pressures than indicated on the data sheet or installation drawing.
  - With hydraulic fluids that do not correspond to the specifications.
  - Higher flow rates than indicated on the data sheet or installation drawing.

Special solutions are available on request!

## 7 Transport

### **⚠ CAUTION**

#### Mishandling, inner mechanics

Due to incorrect handling the internal mechanics can be damaged.

- Do not press the piston out of the body.

### **i NOTE**

#### Transport safety

- Remove the transport safety device only after the product has been mounted!

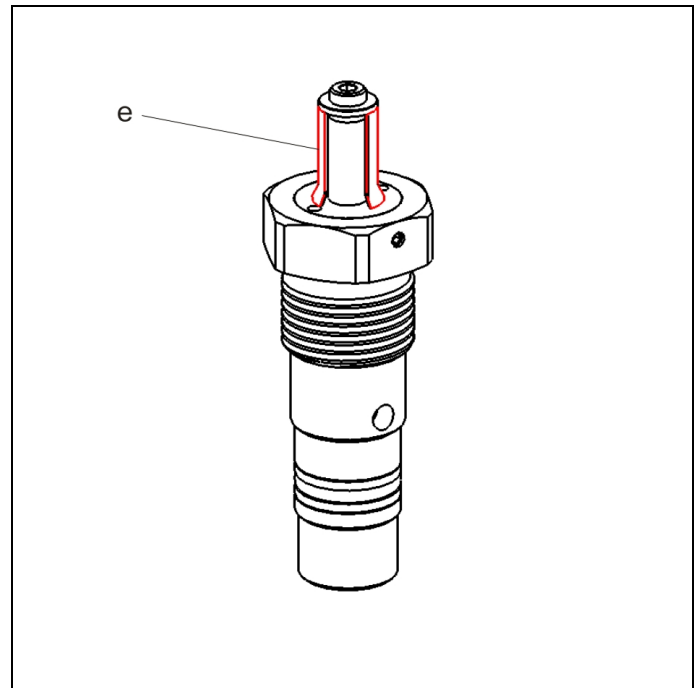

Figure 1: Swing clamp with transport safety device

e	Transport safety device
---	-------------------------

Due to the design the piston can be pressed out of the body. The internal mechanics can be destroyed.

To avoid this, the swing clamp is provided with a transport safety device.

## 8 Installation

### **⚠ WARNING**

#### Injury by high-pressure injection (squirting out of hydraulic oil under high pressure)!

- Improper connection can lead to escapes of oil under high pressure at the connections.
- Mounting or dismounting of the element must only be made in depressurised mode of the hydraulic system.
- Connection of the hydraulic line as per DIN 3852/ISO 1179.
- Unused connections have to be locked professionally.
- Use all mounting holes.

#### Injury by high-pressure injection (squirting out of hydraulic oil under high pressure)!

Wear, damage of the seals, ageing and incorrect mounting of the seal kit by the operator can lead to escapes of oil under high pressure.

- Before using them make a visual control.

#### Injury by falling parts!

- Keep hands and other parts of the body out of the working area.
- Wear personal protection equipment!

#### Poisoning due to contact with hydraulic oil!

Wear, damage of the seals, ageing and incorrect mounting of the seal kit by the operator can lead to escapes of oil.

Incorrect connection can lead to escapes of oil at the ports.

- For handling with hydraulic oil consider the material safety data sheet.
- Wear protection equipment.

## ⚠ CAUTION

### Great weight may fall

Some product types have a considerable weight. These have to be secured against working free during transport. Weight specifications see chapter "Technical characteristics".

### 8.1 Design

This hydraulic clamping element is a pull-type cylinder where a part of the total stroke is used to swing the piston. Thereby the clamping points are free for loading and unloading of the fixture.

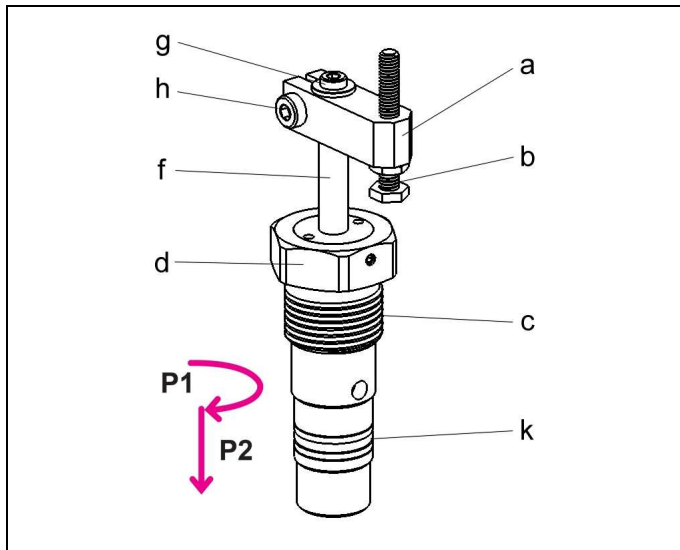

Figure 2: Components

a Clamping arm (accessory)	h Locking screw (accessory)
b Contact bolt (accessory)	k Seals, O-ring and back-up ring (included in delivery)
c Body with thread and hexagon (d)	P1 Swing stroke
f Piston with integrated swing mechanism	P2 Clamping stroke
g Fixing screw with disk	

### 8.2 Swing angle and direction

The swing clamps are available with swing angles of 0° up to 90°. "Swing direction cw" means clockwise rotation, looking from above onto the piston - from the unclamped to the clamped position.

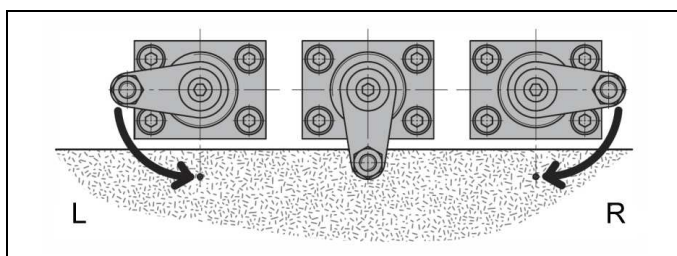

Figure 3: Swing direction  
(L = counterclockwise "ccw", R = clockwise "cw")

### 8.3 Admissible oil flow rate

## ⚠ WARNING

### Injury due to overload of the element

### High-pressure injection (squirting out of hydraulic oil under high pressure) or flying components!

- Due to throttling or closing of ports a pressure intensification can occur.
- Connect the ports professionally!

## ⚠ CAUTION

### Maximum flow rates do not exceed

The maximum flow rate must not be exceeded.

#### 8.3.1 Calculation of the admissible flow rate

##### Admissible oil flow rate

The admissible flow rate or the admissible stroke speed is valid for vertical mounting positions in combination with standard add-on parts as clamping arms or contact bolts, etc.

In case of other mounting positions and/or add-on parts the flow rate has to be reduced.

If the pump flow rate divided by the number of elements is larger than the admissible flow rate of one element, the flow rate has to be throttled.

This prevents an overload and therewith an early failure.

The flow rate can be checked as follows:

$$Q_p \leq 0,06 \cdot \dot{V}_z \cdot n \text{ and/or } Q_p \leq 6 \cdot v_z \cdot A_K \cdot n$$

for clamping elements and work supports (indicated on the data sheets)

##### Maximum piston speed

At specified pump flow rate  $Q$  and with the effective piston area  $A$  the piston speed can be calculated as follows:

$$v_m < \frac{Q_p}{6 \cdot A_K \cdot n}$$

##### Legend

$\dot{V}_z$  = Admissible flow rate of the element in [cm<sup>3</sup>/s]

$Q_p$  = Flow rate of the pump in [l/min]

$A_K$  = Piston area in [cm<sup>2</sup>]

$n$  = Number of elements, same dimensions

$v_z = v_m$  = Admissible/maximum stroke speed in [m/s]

**NOTE**

**Oil volume**

- The maximum oil volume and/or the maximum stroke speed depend on the corresponding product.
  - For clamping cylinders see data sheet A 0.100.
  - or clamping elements, work supports, hydraulic valves, power units and other hydraulic elements indicated on the corresponding data sheets.

Further " things worth knowing about hydraulic cylinders, basics, detailed knowledge and calculations on hydraulic cylinders" see in the [Technical library](#) on the internet!

or download



**8.3.2 Throttling of the flow rate**

The throttling always has to be effected in the supply line to the swing clamp. Only thus pressure intensification and thereby pressures exceeding the operating pressure are avoided. The hydraulic circuit diagram shows flow control valves which allow oil return from the element without any impediments.

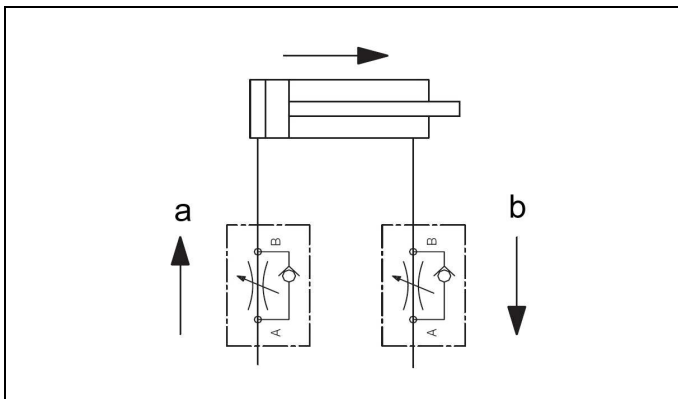

Figure 4: Hydraulic circuit diagram without flow control valves

a Throttling direction	b Free flow
------------------------	-------------

If a return-flow throttling is required due to a negative load, it must be guaranteed that the max. operating pressure (see technical characteristics) will not be exceeded.

**8.4 Transport safety device**

**CAUTION**

**Mishandling, inner mechanics**

Due to incorrect handling the internal mechanics can be damaged.

- Do not press the piston out of the body.

**NOTE**

**Transport safety**

- Remove the transport safety device only after the product has been mounted!

**Removal of the transport safety device**

1. Remove and store fixing screw with disk (g) .
2. Remove transport safety device (e).

**8.5 Installation of products with external sealing**

**8.5.1 Design**

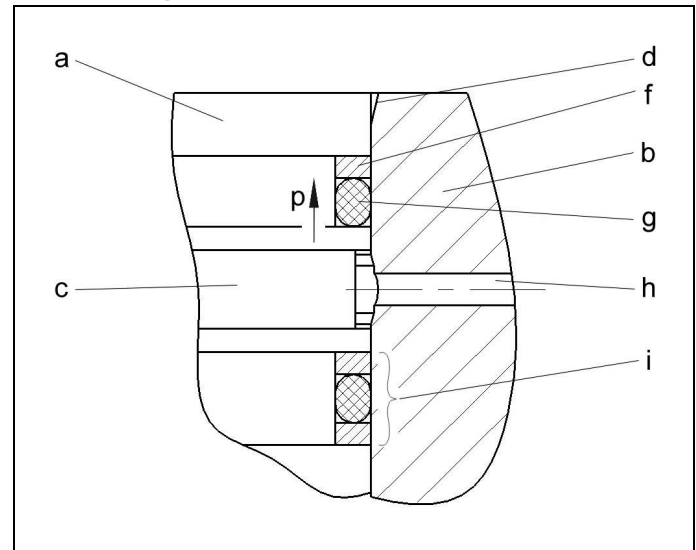

Figure 5: Components

a Body of the element	g O-ring seal
b Fixture body	h Supply bore holes in the fixture body
c Slot to transmit the hydraulic fluid	i Combination for pressure supply from both sides
d Insertion chamfer	p Pressure direction
f Back-up ring remote from the pressure side	

**8.5.2 Installation**

**WARNING**

**Injury by crushing!**

- Due to protruding components there can be pinch points during installation.
- Keep hands and fingers away from pinch points!

**Injury by cutting!**

- Sharp-edged threads can cause cut injuries.
- Wear personal protection equipment!



**For works at and with the product, wear protective gloves!**

Before starting the installation check the following:

- Is the location hole made as per data sheet?
  - Are the indicated tolerances and surfaces kept?
  - Is the wall thickness in the fixture sufficient?
- Are the tapers in the fixture made as per drawing?
- Are the bore holes in the installation geometry are deburred and round?
- Are machining residues as swarf, dirt and foreign particles removed?
- Are crests of threads covered?
- Are seals and components greased or lubricated before installation?
  - Pay attention to compatibility of seals with the medium!
  - It is recommended to use the medium to be sealed for lubrication.
- Do not use grease with additions of solids as molybdenum sulphite or zinc sulphite.

- Do not use sharp objects for installation!
- Pay attention to protruding back-up rings. Use aids for correct positioning.
- Use always installation aids, if possible.

#### Procedure for installation

1. Insert seals.
2. Insert or screw in into location hole.
3. Screw in or fasten, pay attention to smooth running.  
Pay attention that the seals will not be damaged.
4. Fasten with corresponding tightening torque (see general characteristics).  
See chapter Technical characteristics.

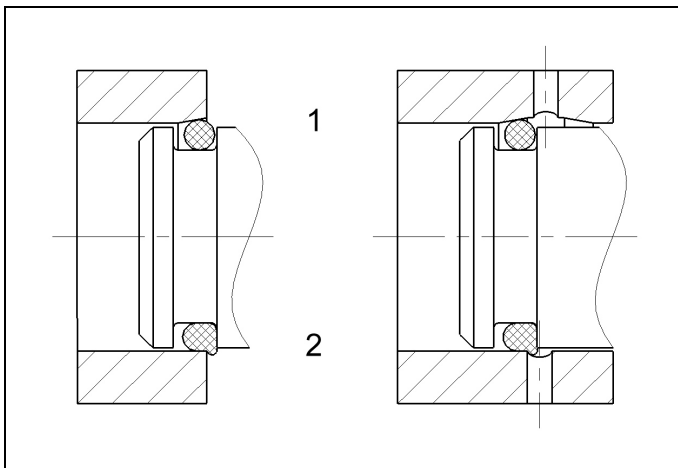

Figure 6: Installation with insertion chamfer and cross hole

- |                        |                             |
|------------------------|-----------------------------|
| 1 Correct with chamfer | 2 Incorrect without chamfer |
|------------------------|-----------------------------|

#### 8.6 Connection of the hydraulic equipment

1. Connect hydraulic lines to qualifying standards and pay attention to scrupulous cleanness (A = Extend, B = Retract)!

#### **i** NOTE

##### More details

- See ROEMHELD data sheets A 0.100, F 9.300, F 9.310 and F 9.360.

##### Screwed Plug

- Use only fittings "screwed plug B and E" as per DIN 3852 (ISO 1179).

##### hydraulic connection

- Do not use sealing tape, copper rings or coned fittings.

##### Pressure fluids

- Use hydraulic oil as per ROEMHELD data sheet A 0.100.

#### 8.7 Assembly and disassembly of the clamping arm

#### **⚠** WARNING

##### Injury by crushing!

Components of the product make a movement while they are in operation.

- This can cause injuries.
- Keep parts of the body and items out of the working area!

#### **⚠** CAUTION

**When tightening and untightening the fixing nut, the piston has to be backed up**

- No torques must be introduced into the piston.
- The conical surfaces of the piston and the clamping arm must be clean and grease free!

#### **i** Note

When tightening and untightening the fixing nut, the clamping arm or the hexagon socket in the piston have to be backed up. It is recommended to effect tightening and untightening in the swing range.

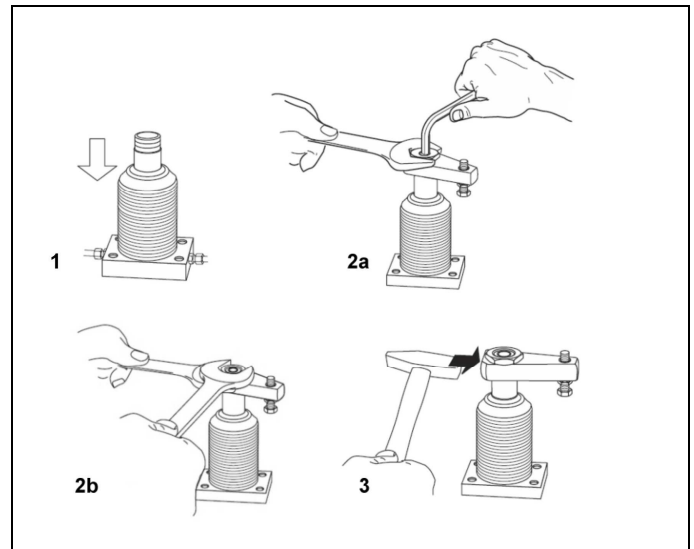

Figure 7: Assembly / disassembly (example)

#### 8.7.1 Assembly of the clamping arm - with pressure

1. Retract piston and pressurise clamping line (port A) (Fig. Assembly, **Pos. 1**).
2. Put the clamping arm in the intended clamping position.
3. Fasten fixing nut and hold clamping arm with an Allen key (Tightening torque of the fixing nut for the clamping arm see technical characteristics. Fig. Assembly, **Pos. 2**).
4. Clamp several times.
5. Check if the clamping point is within the clamping stroke (Fig. Adjustment of the clamping arm, **Pos. 2**).

#### 8.7.2 Assembly of the clamping arm - without pressure

1. Put the clamping arm onto the piston.
2. Move the piston manually to the clamping position.
3. Align clamping arm.
4. Fasten fixing nut with an Allen key and hold the clamping arm with an open-ended wrench (Tightening torque of the fixing nut for the clamping arm see technical characteristics. Fig. Assembly, **Pos. 2**).
5. Clamp several times.
6. Check if the clamping point is within the clamping stroke (Fig. Adjustment of the clamping arm, **Pos. 2**).

## NOTE

### Tightening torque of the fastening nut

- Tightening torque of the fixing nut for the clamping arm see technical characteristics.

### 8.7.3 Disassembly of the clamping arm - without pressure

#### CAUTION

##### Piston rod guide

Heavy hammering can destroy the piston rod guide!

1. Loosen the fixing nut one revolution. Hold the clamping arm with an Allen key (**Pos. 2b**).
2. Hammer **slightly** onto the front face to loosen the clamping arm (**Pos. 3**).

### 8.8 Adjustment of contact bolt

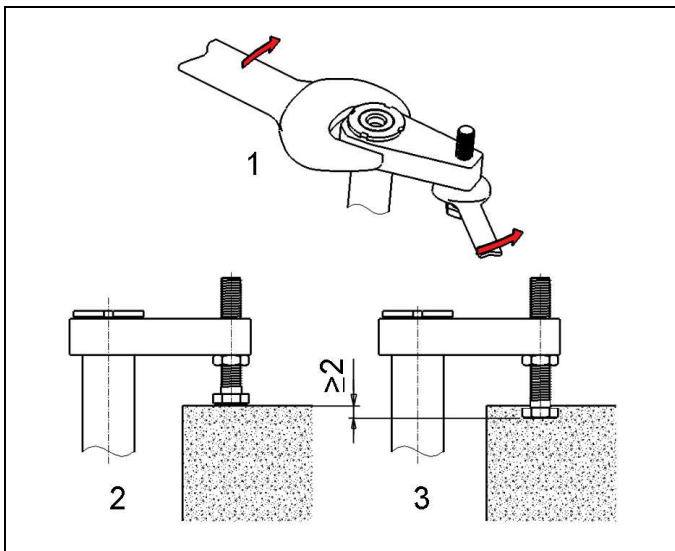

Figure 8: Adjustment of the clamping arm (example)

1. Loosen the lock nut at the contact bolt and completely turn back the contact bolt. (Fig. Adjustment of the clamping arm, **Pos. 1**).
2. Move the clamping arm to the clamping position above the workpiece. (Pay attention to the tolerance of the swing angle)
3. Screw out the contact bolt until it contacts the workpiece. (Fig. Adjustment of the clamping arm, **Pos. 2**).
4. Move the clamping arm back to the unclamping position.
5. Unscrew the contact bolt again by the half of the clamping stroke.
6. Tighten the lock nut at the contact bolt. Hold the clamping arm with an open-ended wrench. (Fig. Adjustment of the clamping arm, **Pos. 1**).

#### 8.8.1 Check adjustment of the contact bolt

1. Move the clamping arm, with throttled flow rate and low pressure to the clamping position onto the workpiece. Pay attention that the contact bolt touches the workpiece only after completion of the swing stroke.
2. Measure and note the distance between clamping arm and upper edge of the workpiece in clamped condition (**Pos. 2**).
3. Unclamp swing clamp again.

4. Unload workpiece out of the fixture.
5. Clamp swing clamp again.
6. Measure the distance as described below item 2. The distance measured now should be at least 2 mm smaller.

## 9 Start up

### WARNING

#### Poisoning due to contact with hydraulic oil!

Wear, damage of the seals, ageing and incorrect mounting of the seal kit by the operator can lead to escapes of oil.

Incorrect connection can lead to escapes of oil at the ports.

- For handling with hydraulic oil consider the material safety data sheet.
- Wear protection equipment.

### CAUTION

#### Operating pressure of 150 bar does not exceed

The maximum operating pressure of 150 bar must not be exceeded.

- Check tight seating (check tightening torque of the fixing screws, see chapter "Technical characteristics").
- Check tight seating of hydraulic connections (check tightening torque of the hydraulic connections, see chapter "Technical characteristics").
- Bleed the hydraulic system.

## NOTE

### Clamping time

- Without bleeding the clamping time will be considerably prolonged and function problems may occur.

- Start up of position monitoring.

## Note

See operating instructions of the position monitoring.

### 9.1 Bleeding of pipe-mounted types

1. Loosen carefully at low pressure union nut of the pipe at the hydraulic ports.
2. Pump until bubble free oil comes out.
3. Fasten union nuts of the pipe.
4. Check tightness.

### 9.2 Bleeding of manifold-mounted types

1. Loosen carefully the bleeding screws of the fixture at low pressure.
2. Pump until bubble free oil comes out.
3. Fasten the bleeding screws.
4. Check correct function.
5. Check sealing of the hydraulic connections!

### 9.3 Admissible operating pressure

#### **NOTE**

##### Various Clamps

- The swing clamps are designed for a maximum pressure (see chapter Technical characteristics).
- According to the version of the used clamping arm, the operating pressure must be reduced considerably.
- Please pay attention to the clamping force diagrams on the data sheet.

## 10 Maintenance

### **WARNING**

#### Burning due to hot surface!

- In operating conditions, surface temperatures of more than 70 °C can appear at the product.
- All maintenance and repair works must only be effected in cooled mode or with safety gloves.

### 10.1 Cleaning

#### **CAUTION**

##### Avoid damages of the moved components

Avoid damages of the moved components (rods, plungers, bolts, etc.) as well as of wiper and seal.

##### Aggressive cleaning agents

The product must not be cleaned with:

- Corrosive or corroding components or
- Organic solvents as halogen or aromatic hydrocarbons and ketones (cellulose thinner, acetone, etc.), because this can destroy the seals.

The product must be cleaned at regular intervals, especially the area of the piston or the plunger housing has to be cleaned from swarf and other liquids.

In the case of heavy contamination, the cleaning has to be made in shorter intervals.

### 10.2 Regular checks

1. Check tightness of hydraulic connections (visual control).
2. Check running surfaces (of the piston rod or bolt) if there are marks and scratches. Traces of marks can be an indication for a contaminated hydraulic system or an inadmissible side load of the block cylinder.
3. Leakage check at the housing - piston rod, bolt or flange.
4. Clamping force control by pressure control.
5. Check if the maintenance intervals are kept.

### 10.3 Exchange seal kit

The exchange of the seal kit is made in case of external leakages. For high availability, the seals have to be changed at the latest after 500,000 cycles or 2 years.

The seal kit is available as spare part. An instruction for the exchange of the seal kit is available on request.

## **NOTE**

#### Seal Kits

- Do not install seal kits which were exposed to light for a longer time.
- Pay attention to the storage conditions (see chapter "Technical characteristics").
- Only use original seals.

## 11 Trouble shooting

Trouble	Cause	Remedy
Piston rod with clamping arm does not retract	Clamping pressure is not available or too low	Check at the pressure generator, if pressure is available and high enough (minimum pressure: 30 bar)
Swing angle is not completely effected or exceeded (tolerance of end position $\pm 2^\circ$ ):	Too much clearance in the swing mechanism	<b>Caution!</b> Repair required by ROEMHELD
	Operating pressure too low	Adjust operating pressure in accordance with the technical characteristics.
Piston rod has too much play:	Guide or piston rod are worn out	Exchange piston rod, exchange component, if required
Clamping pressure reduces due to leakages at the swing clamp:	Wear at the seals	Exchange seals

Trouble	Cause	Remedy
Piston rod with clamping arm does not retract	Clamping pressure is not available or too low	Check at the pressure generator, if pressure is available and high enough (minimum pressure: 30 bar)
Swing angle is not completely effected or exceeded (tolerance of end position $\pm 2^\circ$ ):	Too much clearance in the swing mechanism	<b>Caution!</b> Repair required by ROEMHELD
	Operating pressure too low	Adjust operating pressure in accordance with the technical characteristics.
Piston rod has too much play:	Guide or piston rod are worn out	Exchange piston rod, exchange component, if required
Clamping pressure reduces due to leakages at the swing clamp:	Wear at the seals	Exchange seals



## 12 Technical characteristics

### General characteristics

Types	Maximum operating pressure [bar]	Effective clamping force [kN]	Maximum force to pull [kN]
1848-1X5	150	0.5-0.6*)	0.75

\*) depending on the version of the clamping arm

### Weights

Types	Total stroke [mm]	Weight [kg]
1848-1X5	18	0.12

### **i** NOTE

#### Further information

- For further technical data see ROEMHELD data sheet.

### Proposal, tightening torques for screws of tensile strength 8.8, 10.9, 12.9

### **i** NOTE

The indicated values are approximate values and have to be interpreted according to the user's application!

See note!

Thread	Tightening torque [Nm]		
	8.8	10.9	12.9
M6	10	15	18
M8	25	36	45
M10	49	72	84
M12	85	125	145
M14	135	200	235
M16	210	310	365
M20	425	610	710
M24	730	1050	1220
M30	1,450	2100	2450

**Note:** Valid for workpieces and set screws made of steel with metric thread and connecting surface dimensions as per DIN 912, 931, 933, 934 / ISO 4762, 4014, 4017, 4032

In the table values for tightening torques the following is considered:

Design steel/steel, friction value  $\mu_{ges} = 0.14$  - not oiled, utilisation of the minimum yield point = 90%.

## 13 Accessory

### 13.1 Selection of the clamping arm

### **⚠ CAUTION**

#### Using an incorrect clamping arm

When using incorrect clamping arms, damages can occur.

When selecting the clamping arm, the corresponding operating pressures as shown in the clamping force diagram (see ROEMHELD data sheet) must not be exceeded. If longer clamping arms will be used, not only the operating pressure but also the flow rate has to be reduced.

- Position monitoring

### **i** NOTE

- See ROEMHELD data sheet.

## 14 Storage

### **⚠ CAUTION**

#### Storage of components!

- The product may not be exposed to direct solar radiation, because the UV light can destroy the seals.
- A storage differing from the storage conditions is inadmissible.
- In case of improper storage, the seals can embrittle and resinification of the anti-corrosive oil or corrosion at the element can occur.

The elements are tested by default with mineral oil. The exterior of the elements is treated with a corrosion inhibitor.

The oil film remaining after the test provides for a six-month interior corrosion protection, if stored in dry and uniformly tempered rooms.

For longer storage times, the element has to be filled with a non-resinifying corrosion inhibitor and the outside surfaces must be treated.

## 15 Disposal



### Hazardous to the environment

Due to possible environmental pollution, the individual components must be disposed only by an authorised expert company.

The individual materials have to be disposed as per the existing regulations and directives as well as the environmental conditions.

Special attention has to be drawn to the disposal of components with residual portions of hydraulic fluids. The instructions for the disposal at the material safety data sheet have to be considered.

For the disposal of electrical and electronic components (e.g. stroke measuring systems, proximity switches, etc.) country-specific legal regulations and specifications have to be kept.

The manufacturer commits to transmit the special documents of the products to state authorities on request.

The technical documentation as per appendix VII part B was prepared for the products.

Responsible person for the documentation:  
Dipl.-Ing. (FH) Jürgen Niesner, Tel.: +49(0)6405 89-0.

**Römheld GmbH**

**Friedrichshütte**

Laubach, 28.01.2014

## 16 Declaration of manufacture

### Manufacturer

Römheld GmbH Friedrichshütte  
Römheldstraße 1-5  
35321 Laubach, Germany  
Tel.: +49 (0) 64 05 / 89-0  
Fax: +49 (0) 64 05 / 89-211  
E-mail: info@roemheld.de  
www.roemheld.com

### Declaration of manufacture of the products

Mini swing clamps of data sheet B 1.848.

The following types or part numbers are concerned:

- 1848-105, -115, -125, -135, -145, -155, -165

They are designed and manufactured in line with the relevant versions of the directives **2006/42/EC** (EC MSRL) and in compliance with the valid technical rules and standards.

In accordance with EC-MSRL and EN 982, these products are components that are not yet ready for use and are exclusively designed for the installation in a machine, a fixture or a plant.

According to the pressure equipment directives the products are not to be classified as pressure reservoirs but as hydraulic placing devices, since pressure is not the essential factor for the design, but the strength, the inherent stability and solidity with regard to static or dynamic operating stress.

The products may only be put into operation after it was assessed that the incomplete machine/machine, in which the product shall be installed, corresponds to the machinery directives (2006/42/EC).