

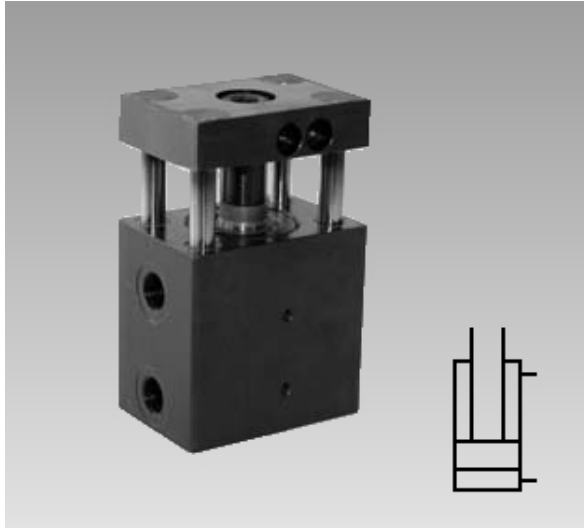

# RM Mini Slide

with optional position monitoring  
double acting, max. operating pressure 500 bar



## 1 Description of the product

The RM mini slide is a compact block cylinder with 4 integrated guide rods which are also in the position to compensate side loads and moments.

Threads can be provided in the front block for fixing of the working loads or tools. To avoid a possible point of squeezing between the front block and the cylinder the safety distance of 2.5mm as per DIN EN 349 is maintained.

The RM mini slides can certainly be delivery equipped with position monitoring by limit switches or inductive sensors.

## 2 Validity of the documentation

This document applies to the following products:

RM mini slides of data sheet B1.7384. The following types or part numbers are concerned:

- RM3-020-10, -11, -12, -13, -14, -15, -16, -17, -18
- RM3-050-10, -11, -12, -13, -14, -15, -16, -17, -18
- RM3-100-10, -11, -12, -13, -14, -15, -16, -17, -18
- RM4-025-10, -11, -12, -13, -14, -15, -16, -17, -18
- RM4-050-10, -11, -12, -13, -14, -15, -16, -17, -18
- RM4-100-10, -11, -12, -13, -14, -15, -16, -17, -18
- RM5-025-10, -11, -12, -13, -14, -15, -16, -17, -18
- RM5-050-10, -11, -12, -13, -14, -15, -16, -17, -18
- RM5-100-10, -11, -12, -13, -14, -15, -16, -17, -18
- RM6-025-10, -11, -12, -13, -14, -15, -16, -17, -18
- RM6-050-10, -11, -12, -13, -14, -15, -16, -17, -18
- RM6-100-10, -11, -12, -13, -14, -15, -16, -17, -18

and its manifold-mounting versions -B.

## 3 Target group of this document

- Specialists, fitters and set-up men of machines and installations with hydraulic expert knowledge.

### Qualification of the personnel

**Expert knowledge** means that the personnel must

- be in the position to read and completely understand technical specifications such as circuit diagrams and product-specific drawing documents,
- have expert knowledge (electric, hydraulic, pneumatic knowledge, etc.) of function and design of the corresponding components.

An **expert** is somebody who has due to its professional education and experiences sufficient knowledge and is familiar with the relevant regulations so that he

- can judge the entrusted works,
- can recognize the possible dangers,
- can take the required measures to eliminate dangers,
- knows the acknowledged standards, rules and guidelines of the technology.
- has the required knowledge for repair and mounting.

## Table of contents

1	Description of the product	1
2	Validity of the documentation	1
3	Target group of this document	1
4	Symbols and signal words	2
5	For your safety	2
6	Application	3
7	Installation	4
8	Start up	7
9	Maintenance	7
10	Trouble shooting	8
11	Technical characteristics	8
12	Accessory	9
13	Storage	10
14	Disposal	10
15	Declaration of manufacture	11

## 4 Symbols and signal words

### **WARNING**

#### Person damage

Stands for a possibly dangerous situation.  
 If it is not avoided, death or very severe injuries will result.

### **CAUTION**

#### Easy injuries / property damage

Stands for a possibly dangerous situation.  
 If it is not avoided, minor injuries or material damages will result.

#### Hazardous to the environment



The symbol stands for important information for the proper handling with materials that are hazardous to the environment.  
 Ignoring these notes can lead to heavy damages to the environment.

### **NOTE**

This symbol stands for tips for users or especially useful information. This is no signal word for a dangerous or harmful situation.

## 5 For your safety

### 5.1 Basic information

The operating instructions serve for information and avoidance of dangers when installing the products into the machine as well as information and references for transport, storage and maintenance.

Only in strict compliance with these operating instructions, accidents and property damages can be avoided as well as trouble-free operation of the products can be guaranteed.

Furthermore, the consideration of the operating instructions will:

- avoid injuries
- reduce down times and repair costs,
- increase the service life of the products.

### 5.2 Safety instructions

### **WARNING**

#### Poisoning due to contact with hydraulic oil!

Wear, damage of the seals, ageing and incorrect mounting of the seal kit by the operator can lead to escapes of oil.  
 Incorrect connection can lead to escapes of oil at the ports.

- For handling with hydraulic oil consider the material safety data sheet.
- Wear protection equipment.

#### Injury by high-pressure injection (squirting out of hydraulic oil under high pressure)!

- Improper connection can lead to escapes of oil under high pressure at the connections.
- Mounting or dismounting of the element must only be made in depressurised mode of the hydraulic system.
- Connection of the hydraulic line as per DIN 3852/ISO 1179.
- Unused connections have to be locked professionally.
- Use all mounting holes.

#### Injury by high-pressure injection (squirting out of hydraulic oil under high pressure)!

Wear, damage of the seals, ageing and incorrect mounting of the seal kit by the operator can lead to escapes of oil under high pressure.

- Before using them make a visual control.

### **CAUTION**

#### Operating pressure of 500 bar does not exceed

The maximum operating pressure of 500 bar must not be exceeded.

#### High forces are generated!

With hydraulic pressure very high forces are generated.

- The fixture or machine must be in the position to compensate these forces.

#### Damage of components!

- The guide rods are not secured and can fall out or get stuck.
- The products must not be operated only with the front block or without working load.
- The tool fixing plate has to be designed so that all guide rods are at least partially covered.

### **NOTE**

#### Qualification of personnel

All works may only be effected by qualified personnel familiar with the handling of hydraulic components.

### 5.3 Special safety notes

#### **WARNING**

##### **Injury by crushing!**

Components of the product make a movement while they are in operation.

- This can cause injuries.
- Keep parts of the body and items out of the working area!

The distance bushing mounted at the factory provides a safety distance of 25mm between the front block and the cylinder to avoid squeezing of the fingers. A complete protection is however only possible by mounting further safety devices, which is the responsibility of the machine tool manufacturer.

If the RM mini slide is secured so that injuries of the operator are excluded even in the setting mode, the distance bushing can be removed. The total length is reduced by 15 up to 18 mm.

## 6 Application

### 6.1 Intended use

#### **CAUTION**

##### **Operating pressure > 100 bar provide support, straight pins**

- For an operating pressures of more than 100 bar, the products must be supported against the effective direction to compensate the occurring forces.
- Screws for fixing can be damaged.

The products are used in industrial applications to transform hydraulic pressure to a linear movement and /or force. They must only be operated with hydraulic oil.

Furthermore the following belongs to possible uses:

- Use within the capacity indicated in the technical characteristics (see data sheet).
- Use as per operating instructions.
- Compliance with service intervals.
- Qualified and trained personnel for the corresponding activities.
- Mounting of spare parts only with the same specifications as the original part.

### 6.2 Misapplication

#### **WARNING**

##### **Injuries, material damages or malfunctions!**

- Do not modify the product!

The use of these products is not admitted:

- For domestic use.
- On pallets or machine tool tables in primary shaping and metal forming machine tools.
- If due to vibrations or other physical / chemical effects damages of the products or seals can be caused.
- In machines, on pallets or machine tool tables that are used to change the characteristics of the material (magnetise, radiation, photochemical procedures, etc.).
- In areas for which special guidelines apply, especially installations and machines:
  - For the use on fun fairs and in leisure parks.
  - In food processing or in areas with special hygiene regulations.
  - For military purposes.
  - In mines.
  - In explosive and aggressive environments (e.g. ATEX).
  - In medical engineering.
  - In the aerospace industry.
  - For passenger transport.
- For other operating and environmental conditions e.g.:
  - Higher operating pressures than indicated on the data sheet or installation drawing.
  - With hydraulic fluids that do not correspond to the specifications.
  - Higher flow rates than indicated on the data sheet or installation drawing.

**Special solutions are available on request!**

## 7 Installation

### ⚠ CAUTION

#### Damage of components!

- The guide rods are not secured and can fall out or get stuck.
- The products must not be operated only with the front block or without working load.
- The tool fixing plate has to be designed so that all guide rods are at least partially covered.

### 7.1 Design

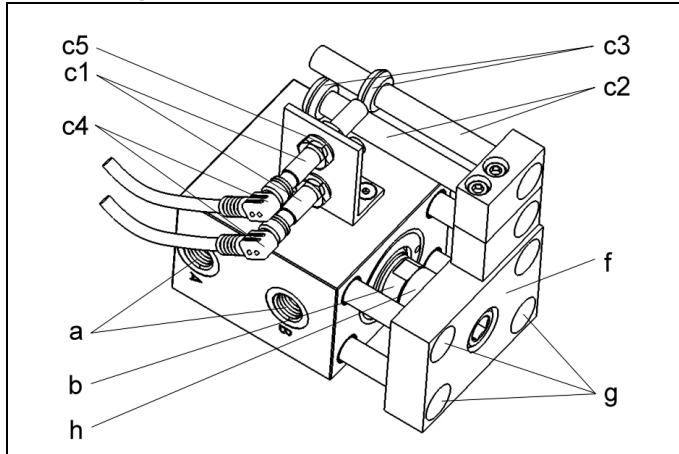

Figure 1: Components, double inductive monitoring (optional)

a Hydraulic port (A extend, B retract)	c3 Control cams
b Piston rod	c4 Right angle plugs
c1 Inductive proximity switch	c5 Lock nut
c2 Switch rods	f Front block
	g Guide rods
	h Distance bushing

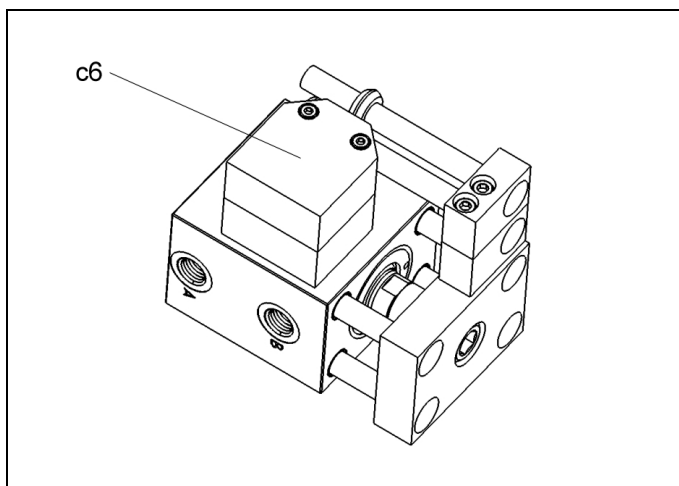

Figure 2: Components, double limit switch monitoring (optional)

c6 Limit switch monitoring	
----------------------------	--

### 7.2 Mounting types

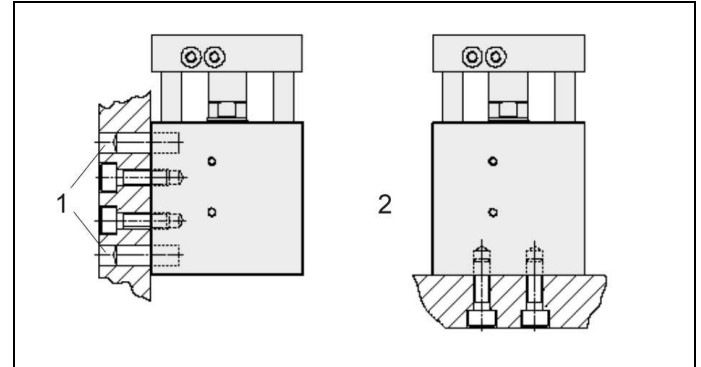

Figure 3: Fixing possibility and support

1 Support by dowel pins	2 Support against the effective direction
-------------------------	---

### 7.3 Assembly / disassembly of the front block

#### NOTE

#### Guide rods are not secured

- The guide rods are not secured in the front block. The customer must secure all four guide rods by means of a mounted tool fixing plate.

Additional mounting holes can be drilled into the delivered front block. These mounting holes may only be drilled into the detached front block.

#### 7.3.1 Disassembly

1. Expel the guide rods in **retracted** position by punching to the side of the front block.
2. Loosen fixing screw of the piston rod.
3. Detach front block.

#### 7.3.2 Installation

1. Clean contact surface.
2. Put the front block.
3. Fasten hand-tight the fixing screws of the piston rod.
4. Carefully beat in the guide rods.
5. Tighten fixing screws of the piston rod with the prescribed tightening torque (see Technical characteristics).

### 7.4 Support of the product

#### ⚠ CAUTION

##### Operating pressure > 100 bar provide support, straight pins

- For an operating pressures of more than 100 bar, the products must be supported against the effective direction to compensate the occurring forces.
- Screws for fixing can be damaged.

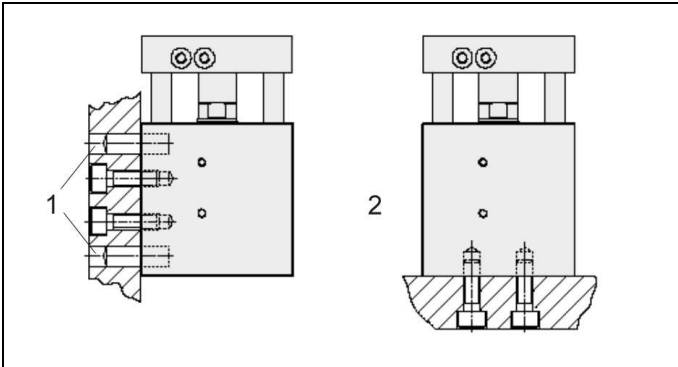

Figure 4: Fixing possibility and support

1 Support by dowel pins	2 Support against the effective direction
-------------------------	---

### 7.5 Admissible oil flow rate

#### ⚠ WARNING

##### Injury due to overload of the element

##### High-pressure injection (squirting out of hydraulic oil under high pressure) or flying components!

- Due to throttling or closing of ports a pressure intensification can occur.
- Connect the ports professionally!

#### ⚠ CAUTION

##### Maximum flow rates do not exceed

The maximum flow rate must not be exceeded.

#### 7.5.1 Calculation of the admissible flow rate

##### Admissible oil flow rate

The admissible flow rate or the admissible stroke speed is valid for vertical mounting positions in combination with standard add-on parts as clamping arms or contact bolts, etc.

In case of other mounting positions and/or add-on parts the flow rate has to be reduced.

If the pump flow rate divided by the number of elements is larger than the admissible flow rate of one element, the flow rate has to be throttled.

This prevents an overload and therewith an early failure.

The flow rate can be checked as follows:

$$Q_p \leq 0,06 \cdot \dot{V}_Z \cdot n \text{ and/or } Q_p \leq 6 \cdot v_Z \cdot A_K \cdot n$$

for clamping elements and work supports (indicated on the data sheets)

#### Maximum piston speed

At specified pump flow rate  $Q$  and with the effective piston area  $A$  the piston speed can be calculated as follows:

$$v_m < \frac{Q_p}{6 \cdot A_K \cdot n}$$

#### Legend

- $\dot{V}_Z$  = Admissible flow rate of the element in [cm<sup>3</sup>/s]
- $Q_p$  = Flow rate of the pump in [l/min]
- $A_K$  = Piston area in [cm<sup>2</sup>]
- $n$  = Number of elements, same dimensions
- $v_Z = v_m$  = Admissible/maximum stroke speed in [m/s]

#### NOTE

##### Oil volume

- The maximum oil volume and/or the maximum stroke speed depend on the corresponding product.
  - For clamping cylinders see data sheet A 0.100.
  - or clamping elements, work supports, hydraulic valves, power units and other hydraulic elements indicated on the corresponding data sheets.

Further "things worth knowing about hydraulic cylinders, basics, detailed knowledge and calculations on hydraulic cylinders" see in the [Technical library](#) on the internet!

or download



#### 7.5.2 Throttling of the flow rate

The throttling always has to be effected in the supply line to the swing clamp. Only thus pressure intensification and thereby pressures exceeding the operating pressure are avoided. The hydraulic circuit diagram shows flow control valves which allow oil return from the element without any impediments.

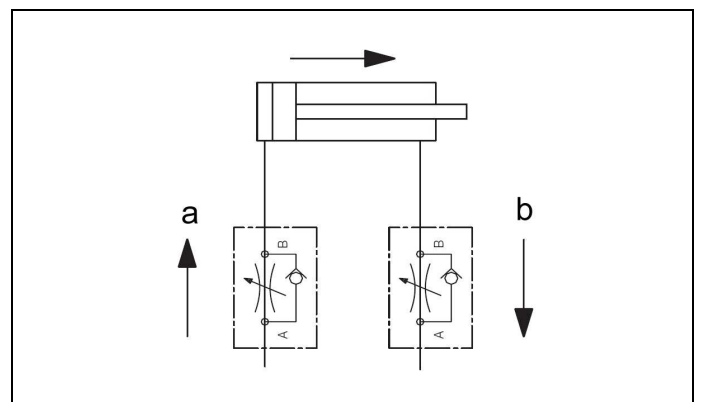

Figure 5: Hydraulic circuit diagram without flow control valves

a Throttling direction	b Free flow
------------------------	-------------

If a return-flow throttling is required due to a negative load, it must be guaranteed that the max. operating pressure (see technical characteristics) will not be exceeded.

### 7.6 Installation of pipe-mounted types

1. Clean the support surfaces.
2. Fasten the element support at the flange surface (see figure "Mounting types").

#### **WARNING**

##### Injury by falling products!

Safety shoes have to be worn to avoid injuries due to falling objects.

#### **NOTE**

##### Tightening

- To determine the tightening torque of the fixing screws a screw calculation as per VDI 2230 page 1 has to be effected. The screw material is indicated in the chapter "Technical characteristics".

#### **NOTE**

##### Tightening torques

- The tightening torques for the fixing screws have to be designed with reference to the application (e. g. as per VDI 2230).

Proposals and approximate values for the tightening torques see chapter "Technical characteristics".

### 7.7 Installation of manifold-mounted types

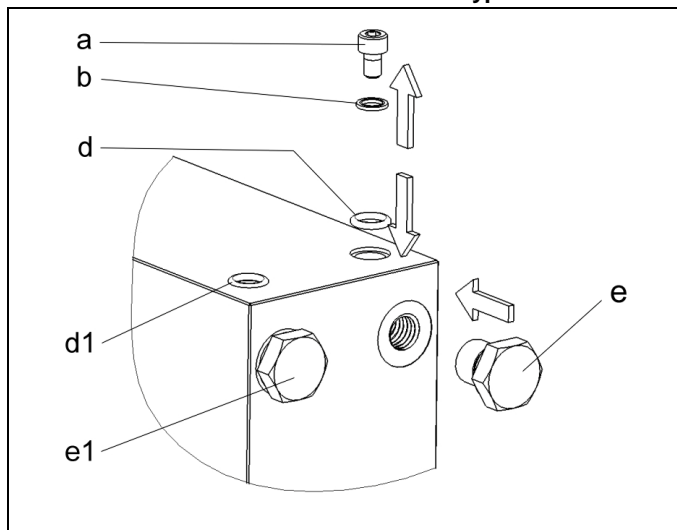

Figure 6: Example, preparation for hydraulic ports without pipes

#### **NOTE**

##### The arrangement of the ports

- The shown figure is a schematic diagram. The arrangement of the ports depends on the respective product (see chapter "Design").

a	Socket head cap screw	d1	Mounted O-ring
b	Sealing ring	e	Screw plug (accessory)
d	O-ring (accessory, depending on the version)	e1	Mounted screw plug

1. Drill the holes for hydraulic oil supply and return in the fixture (see also data sheet).

2. Grind or finish mill the manifold-mounting surface ( $R_a \geq 0.8$  and a flatness of 0.04 mm to 100 x 100 mm, marks, scratches, shrink holes, concentric machining marks are inadmissible).

For some versions:

- 3a. Remove socket head cap screws and sealing rings, insert o-rings (accessories, if required).
- 3b. Tighten pipe ports with screw plugs (accessories, if required)
4. Clean the support surfaces.
5. Position and fasten on the fixture.
6. Install bleeding screws at the upper ends of the piping.

#### **NOTE**

##### Tightening torques

- The tightening torques for the fixing screws have to be designed with reference to the application (e. g. as per VDI 2230).

Proposals and approximate values for the tightening torques see chapter "Technical characteristics".

### 7.8 Connection of the hydraulic equipment

1. Connect hydraulic lines to qualifying standards and pay attention to scrupulous cleanness (A = Extend, B = Retract)!

#### **NOTE**

##### More details

- See ROEMHELD data sheets A 0.100, F 9.300, F 9.310 and F 9.360.

##### Screwed Plug

- Use only fittings "screwed plug B and E" as per DIN 3852 (ISO 1179).

##### hydraulic connection

- Do not use sealing tape, copper rings or coned fittings.

##### Pressure fluids

- Use hydraulic oil as per ROEMHELD data sheet A 0.100.

### 7.9 Leakage due to the system

The piston rod is set in motion by the hydraulic oil to perform the clamping task.

The hydraulic oil must be sealed at the piston rod to the atmosphere. During extension of the piston rod, the hydraulic oil must remain in the cylinder.

For ROEMHELD products, sealing systems are used for the piston rod, generally consisting of several sealing elements. Those sealing systems enable the sealing points to be absolutely leak-proof in the total specified pressure area, when the system is not in operation. Neither does oil escape at the piston rod, nor is oil transferred from the piston side and piston rod side.

**Important:** ROEMHELD products do not leak oil when static. To ensure an adequate working life, the sealing systems must be lubricated by the hydraulic fluid while in motion, in dynamic operation. Since the hydraulic fluid must reach the sealing lip, a certain amount of oil is lost from leakage, in the process. According to the used sealing and the corresponding application conditions the amount can be very different depending on the product group. However the leakage should be very little (see A 0.100 General characteristics of hydraulic equipment).

**Leakage-free cylinders (leakage re-circulation or special sealing) are available on request.**

## 8 Start up

### WARNING

#### Poisoning due to contact with hydraulic oil!

Wear, damage of the seals, ageing and incorrect mounting of the seal kit by the operator can lead to escapes of oil.

Incorrect connection can lead to escapes of oil at the ports.

- For handling with hydraulic oil consider the material safety data sheet.
- Wear protection equipment.

### CAUTION

#### Operating pressure of 500 bar does not exceed

The maximum operating pressure of 500 bar must not be exceeded.

- Check tight seating (check tightening torque of the fixing screws, see chapter "Technical characteristics").
- Check tight seating of hydraulic connections (check tightening torque of the hydraulic connections, see chapter "Technical characteristics").
- Bleed the hydraulic system.

### NOTE

#### Clamping time

- Without bleeding the clamping time will be considerably prolonged and function problems may occur.

- Start up of position monitoring.

### NOTE

See operating instructions of the position monitoring.

## 8.1 Bleeding of pipe-mounted types

1. Loosen carefully at low pressure union nut of the pipe at the hydraulic ports.
2. Pump until bubble free oil comes out.
3. Fasten union nuts of the pipe.
4. Check tightness.

## 8.2 Bleeding of manifold-mounted types

1. Loosen carefully the bleeding screws of the fixture at low pressure.
2. Pump until bubble free oil comes out.
3. Fasten the bleeding screws.
4. Check correct function.
5. Check sealing of the hydraulic connections!

## 9 Maintenance

### WARNING

#### Burning due to hot surface!

- In operating conditions, surface temperatures of more than 70 °C can appear at the product.
- All maintenance and repair works must only be effected in cooled mode or with safety gloves.

#### Injury by crushing!

- Due to the stored energy, an unexpected start of the product can occur.
- Maintenance works at the product must only be made in depressurised mode!
- Keep hands and other parts of the body out of the working area!

## 9.1 Cleaning

### CAUTION

#### Avoid damages of the moved components

Avoid damages of the moved components (rods, plungers, bolts, etc.) as well as of wiper and seal.

#### Aggressive cleaning agents

The product must not be cleaned with:

- Corrosive or corroding components or
- Organic solvents as halogen or aromatic hydrocarbons and ketones (cellulose thinner, acetone, etc.), because this can destroy the seals.

The product must be cleaned at regular intervals, especially the area of the piston or the plunger housing has to be cleaned from swarf and other liquids.

In the case of heavy contamination, the cleaning has to be made in shorter intervals.

## 9.2 Regular checks

1. Check tightness of hydraulic connections (visual control).
2. Check running surfaces (of the piston rod or bolt) if there are marks and scratches. Traces of marks can be an indication for a contaminated hydraulic system or an inadmissible side load of the block cylinder.
3. Leakage check at the housing - piston rod, bolt or flange.
4. Clamping force control by pressure control.
5. Check if the maintenance intervals are kept.

### 9.3 Exchange seal kit

The exchange of the seal kit is made in case of external leakages. For high availability, the seals have to be changed at the latest after 1,000,000 cycles or 2 years.

The seal kit is available as spare part. An instruction for the exchange of the seal kit is available on request.

#### **NOTE**

##### Seal Kits

- Do not install seal kits which were exposed to light for a longer time.
- Pay attention to the storage conditions (see chapter "Technical characteristics").
- Only use original seals.

## 10 Trouble shooting

Trouble	Cause	Remedy
Piston does not extend:	Hydraulic oil supply or return is impeded	Check and blow through tubes or channels.
Piston extends jerkily:	Air in the hydraulic system	Hydraulic bleeding
System pressure drops:	Hydraulic ports leaky	Seal
	Wear of the seals	Replace sealing rings.
Limit or proximity switch does not switch off	Switch wrongly wired	Check cabling
	Operating button of the switch is not operated by the control cam	Check whether control cam is firmly mounted
		Stroke end will not be obtained
		Only for proximity switches: Distance to control cam too big

## 11 Technical characteristics

### General characteristics

Types	Max. operating pressure [bar]	Max. force to push [kN]	Max. force to pull [kN]	Tightening torques fixing screw piston rod [Nm]
RM3-XXX-XX	500	24.5	14.5	45
RM4-XXX-XX	500	40.2	24.5	80
RM5-XXX-XX	500	62.8	38.3	200
RM6-XXX-XX	500	98.5	57.9	400

### Weights

Types	Stroke [mm]	Weight [kg]
RM3-020-1X	20	1.6
RM3-050-1X	50	2.2
RM3-100-1X	100	3.8
RM4-020-1X	25	2.8
RM4-050-1X	50	3.7
RM4-100-1X	100	5.5
RM5-020-1X	25	4.1
RM5-050-1X	50	5.1
RM5-100-1X	100	7.1
RM6-020-1X	25	6.4
RM6-050-1X	50	7.8
RM6-100-1X	100	10.8

The indicated weights can deviate according to the version.

### Proposal, tightening torques for screws of tensile strength 8.8, 10.9, 12.9

#### **NOTE**

The indicated values are approximate values and have to be interpreted according to the user's application!  
See note!

Thread	Tightening torque [Nm]		
	8.8	10.9	12.9
M6	10	15	18
M8	25	36	45
M10	49	72	84
M12	85	125	145
M14	135	200	235
M16	210	310	365
M20	425	610	710
M24	730	1050	1220
M30	1,450	2100	2450

**Note:** Valid for workpieces and set screws made of steel with metric thread and connecting surface dimensions as per DIN 912, 931, 933, 934 / ISO 4762, 4014, 4017, 4032

In the table values for tightening torques the following is considered:

Design steel/steel, friction value  $\mu_{ges} = 0.14$  - not oiled, utilisation of the minimum yield point = 90%.

#### **NOTE**

##### Further information

- For further technical data see ROEMHELD data sheet.



## 12 Accessory

### 12.1 Electronic proximity sensor

For position monitoring inductive proximity switches or mechanical limit switches can be used.

Condition for start up is that the proximity switches or limit switches S1 and S2 are electrically wired as per circuit diagram and a correct supply voltage is available.

If two positions will be controlled the proximity switches or limit switches are described as S1 and S2. If only one position will be controlled, only S2 is available (S1 is omitted).

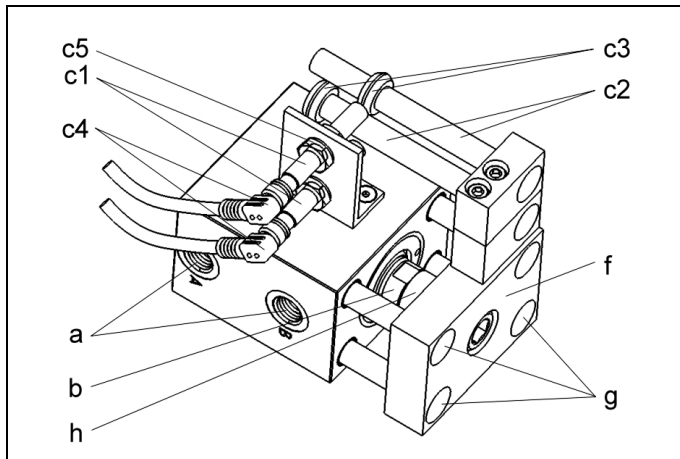

Figure 7: Components, double inductive monitoring (optional)

a Hydraulic port (A extend, B retract)	c3 Control cams
b Piston rod	c4 Right angle plugs
c1 Inductive proximity switch	c5 Lock nut
c2 Switch rods	f Front block
	g Guide rods
	h Distance bushing

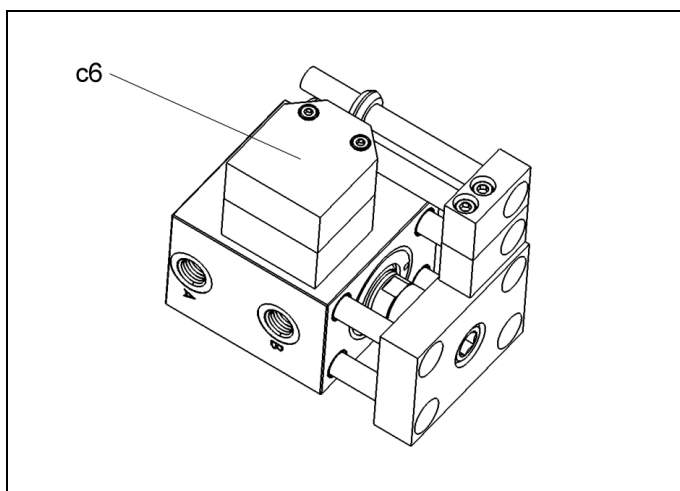

Figure 8: Components, double limit switch monitoring (optional)

c6 Limit switch monitoring	
----------------------------	--

### 12.1.1 Start up

#### **⚠ WARNING**

#### Injury by high-pressure injection due to damage of the sensor sealing!

- Moisten the seals slightly with oil in order to ease the assembly. When screwing in pay attention to possible resistance.

Condition for start up is that the proximity sensors are electrically wired as per circuit diagram and a correct supply voltage is available.

- Completely extend piston.
- Push the control cam onto the switch rod to switch S2 and fix it.

#### Only for proximity switches:

- Fasten proximity switch S2 with 2 lock nuts so that the distance to the control cam is 0,5mm. Position control cam in the desired switching position and fix it by a headless screw.
- If two positions are monitored, retract the piston and mount S1 in the same way.

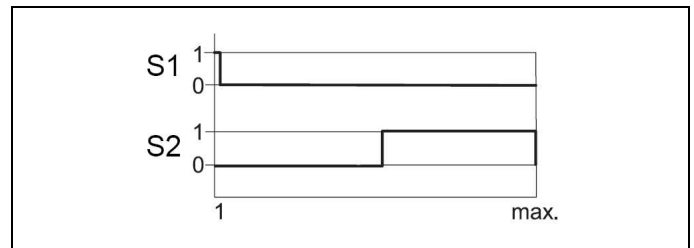

Figure 9: Signal course - clamping

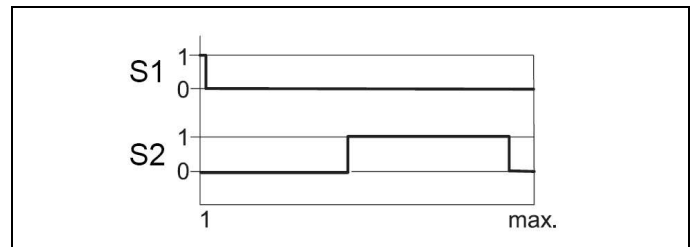

Figure 10: Signal course - unclamping

1 Signal ON	0 Signal OFF
-------------	--------------

The two figures show the signal course at both proximity switches during a clamping and unclamping process (max. = total stroke).

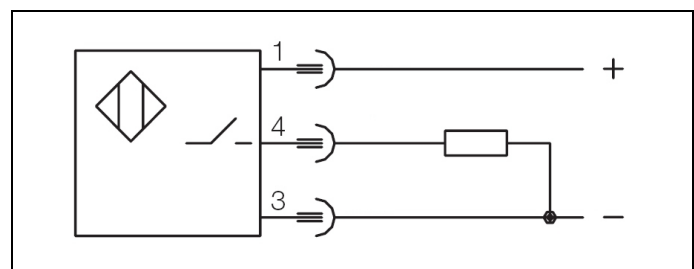

Fig. 11: circuit diagram for pnp (+) magnetic sensor

1 brown +
3 blue -
4 black

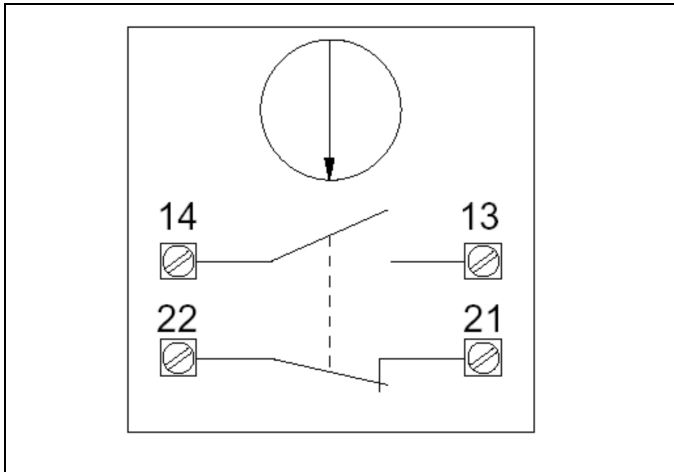

Figure 12: Circuit diagram for limit switches

14 → 13 - NO = Normally Open (interlock)	22 → 21 - NC = Normally Closed (break contact)
--	--

### 12.1.2 Technical data / proximity sensor

Environmental temperature:	-25 °C to +80 °C	-25 °C to +120 °C
Rated operating distance Sn:	1.5 mm	1.5 mm
Secured operating distance:	0 ... 1.2 mm	0 ... 2.0 mm
Hysteresis:	max. 15 %	max. 15 %
Repetitive accuracy:	max. 5%	max. 5%
Body material:	1.4104 steel, corrosion resistant	
Code class:	IP 68	IP 68
Connection type:	plug S4	plug S4
Voltage:	DC	DC
Switching function:	interlock	interlock
Output:	<b>pnp</b>	<b>pnp</b>
Operating voltage UB:	10 ... 30 V	10 ... 30 V
Design voltage:	24 V	24 V
Design current:	200 mA	200 mA
Residual ripple:	max. 15%	max. 15%
Switching frequency	1 kHz	2 kHz
Protection against reverse battery:	installed	installed
Protected against short circuits	yes	yes

### 12.1.3 Technical characteristics / stroke end sensor

Switch off power	24V / 2A
Switching voltage, min.	12V
Switching current, min.	10 mA (at 12 V)
Operating temperature	-5 ... +80 °C

#### **NOTE**

Further technical data with reference to the position monitoring are included in the data sheet.

## 12.2 Further accessory

#### **NOTE**

- Position monitoring

#### **NOTE**

- See ROEMHELD data sheet.

## 13 Storage

### **CAUTION**

#### Storage of components!

- The product may not be exposed to direct solar radiation, because the UV light can destroy the seals.
- A storage differing from the storage conditions is inadmissible.
- In case of improper storage, the seals can embrittle and resinification of the anti-corrosive oil or corrosion at the element can occur.

The elements are tested by default with mineral oil. The exterior of the elements is treated with a corrosion inhibitor.

The oil film remaining after the test provides for a six-month interior corrosion protection, if stored in dry and uniformly tempered rooms.

For longer storage times, the element has to be filled with a non-resinifying corrosion inhibitor and the outside surfaces must be treated.

## 14 Disposal



#### Hazardous to the environment

Due to possible environmental pollution, the individual components must be disposed only by an authorised expert company.

The individual materials have to be disposed as per the existing regulations and directives as well as the environmental conditions.

Special attention has to be drawn to the disposal of components with residual portions of hydraulic fluids. The instructions for the disposal at the material safety data sheet have to be considered.

For the disposal of electrical and electronic components (e.g. stroke measuring systems, proximity switches, etc.) country-specific legal regulations and specifications have to be kept.

## 15 Declaration of manufacture

### Manufacturer

Römheld GmbH Friedrichshütte  
Römheldstraße 1-5  
35321 Laubach, Germany  
Tel.: +49 (0) 64 05 / 89-0  
Fax: +49 (0) 64 05 / 89-211  
E-mail: info@roemheld.de  
www.roemheld.com

### Declaration of manufacture of the products

RM mini slides of data sheet B1.7384. The following types or part numbers are concerned:

- RM3-020-10, -11, -12, -13, -14, -15, -16, -17, -18
- RM3-050-10, -11, -12, -13, -14, -15, -16, -17, -18
- RM3-100-10, -11, -12, -13, -14, -15, -16, -17, -18
- RM4-025-10, -11, -12, -13, -14, -15, -16, -17, -18
- RM4-050-10, -11, -12, -13, -14, -15, -16, -17, -18
- RM4-100-10, -11, -12, -13, -14, -15, -16, -17, -18
- RM5-025-10, -11, -12, -13, -14, -15, -16, -17, -18
- RM5-050-10, -11, -12, -13, -14, -15, -16, -17, -18
- RM5-100-10, -11, -12, -13, -14, -15, -16, -17, -18
- RM6-025-10, -11, -12, -13, -14, -15, -16, -17, -18
- RM6-050-10, -11, -12, -13, -14, -15, -16, -17, -18
- RM6-100-10, -11, -12, -13, -14, -15, -16, -17, -18

and its manifold-mounting versions -B.

They are designed and manufactured in line with the relevant versions of the directives **2006/42/EC** (EC MSRL) and in compliance with the valid technical rules and standards.

In accordance with EC-MSRL and EN 982, these products are components that are not yet ready for use and are exclusively designed for the installation in a machine, a fixture or a plant.

According to the pressure equipment directives the products are not to be classified as pressure reservoirs but as hydraulic placing devices, since pressure is not the essential factor for the design, but the strength, the inherent stability and solidity with regard to static or dynamic operating stress.

The products may only be put into operation after it was assessed that the incomplete machine/machine, in which the product shall be installed, corresponds to the machinery directives (2006/42/EC).

The manufacturer commits to transmit the special documents of the products to state authorities on request.

The technical documentation as per appendix VII part B was prepared for the products.

Responsible person for the documentation:  
Dipl.-Ing. (FH) Jürgen Niesner, Tel.: +49(0)6405 89-0.

**Römheld GmbH**  
**Friedrichshütte**  
Laubach, 10.12.2013